

TEAC®

**SERVICE
MANUAL
A-6600**

Stereo Tape Deck



TEAC CORPORATION

51032140

1. GENERAL DESCRIPTION

The TEAC A-6600 open reel tape deck is a 1/4 track, 2 channel (stereo) tape deck which has forward record/play capability and also reverse play capability. The A-6600 operates at two selectable speeds, 7-1/2 ips and 3-3/4 ips. It can be used with reels up to a maximum 10-1/2" diameter. It employs a DC Servo Controlled capstan motor and has dual pinch roller and capstan systems and dual impedance rollers.



— Table of Contents —

1. GENERAL DESCRIPTION	3
2. SPECIFICATION AND SERVICE DATA	4
3. TOOLS FOR TESTING AND MAINTENANCE	5
4. PARTIAL DIS-ASSEMBLY	6
5. TAPE TRANSPORT PARTS LOCATION	11
6. HEAD REPLACEMENT AND ALIGNMENT	12
— Mechanical —	
7. MEASUREMENT AND ADJUSTMENT	14
— Mechanical —	
8. MEASUREMENT AND ADJUSTMENT	18
— Electrical —	
9. SERVICING AND MAINTENANCE	25
10. SIMPLIFIED SCHEMATIC AND LEVEL DIAGRAMS	26
11. THEORY OF OPERATION	27

2. SPECIFICATIONS AND SERVICE DATA

2-1 SPECIFICATIONS

Track System	1/4 track, 2 channel stereophonic 1/4 track, 1 channel monophonic
Heads	Four; Erase, Record, Forward Play and Reverse Play
Reel Size	10-1/2" and 7"
Tape Speed	7-1/2 ips and 3-3/4 ips
3 Motors	1 DC Servo Controlled Capstan Motor, 2 Eddy Current Induction Reel motors
Input (Level and Impedance)	MIC: Specified; -60 dB (0.774 mV)/10k ohms Minimum; -70 dB (0.244 mV) LINE: Specified; -12 dB (194 mV)/50k ohms Minimum; -22 dB (61.5 mV)
Output (Level and Load Impedance)	LINE: Specified; -5 dB (435 mV)/10k ohms Maximum; +1 dB (869 mV) Headphone out: -19 dB (86 mV) /8 ohms
Playback Equalization	7-1/2 ips: 3180 μ sec + 50 μ sec (NAB) 3-3/4 ips: 3180 μ sec + 90 μ sec (NAB)
Bias Frequency	100k Hz (\pm 5k Hz, push-pull oscillator)
Power Requirement and Consumption	100, 117, 220, 240 V AC 50/60 Hz (General Export model), 144W 117 V AC 60 Hz (U.S.A. and Canada Model), 154W
Weight	30.5 kg (67 lbs) net
Dimensions (WHD)	476 x 549 x 258 mm (18-3/4" x 21-5/8" x 10-3/16")

2-2 SERVICE DATA —MECHANICAL—

Tape Speed Deviation and Drift	3,000 Hz \pm 30 Hz, within 15 Hz	Auto specer time: Min. — 3 sec Max. — 10 sec
Wow and Flutter	Playback: 0.18% (RMS) at 7-1/2 ips 0.20% (RMS) at 3-3/4 ips Overall: 0.20% (RMS) at 7-1/2 ips 0.25% (RMS) at 3-3/4 ips	
Pinch Roller Pressure	2.2 kg (4.8 lbs)	
Reel Torque		

	REEL SW	TAKE UP VALUES
FWD	LARGE	680 to 720 g-cm (9.5 to 10 oz-inch)
	SMALL	350 to 450 g-cm (5.0 to 6.3 oz-inch)
REV	LARGE	650 to 750 g-cm (9.0 to 11 oz-inch)
	SMALL	350 to 450 g-cm (5.0 to 6.3 oz-inch)

	REEL SW	BACK TENSION VALUES
FWD	LARGE	380 to 420 g-cm (5.3 to 6.0 oz-inch)
	SMALL	230 to 270 g-cm (3.2 to 4.0 oz-inch)
REV	LARGE	350 to 450 g-cm (5.0 to 6.3 oz-inch)
	SMALL	200 to 300 g-cm (3.0 to 4.0 oz-inch)

Brake Torque	1,600 to 2,000 g-cm (22.4 to 28.0 oz-inch)
F.F/REW Time	160 seconds for 1,800 foot tape

2-3 SERVICE DATA —ELECTRICAL—

Frequency Response	Refer to Frequency Response Limits charts in this manual
Signal-To-Noise Ratio	Overall: 49 dB at 7-1/2 ips 46 dB at 3-3/4 ips
Erase Efficiency	70 dB at 1k Hz signal (Measurement with input 10 dB higher than the Specified Input level)
Cross Talk Rejection	40 dB adjacent track at 125 Hz
Stereo Channel Separation	50 dB Channel to Channel at 1k Hz
Total Harmonic Distortion	Overall: 0.8% at 1k Hz signal at 0 VU.

NOTE: As a result of continuing changes and improvements during the production run, minor differences may be found between early and later machines. Value of "dB" in this manual refers to 0 dB = 0.775V.

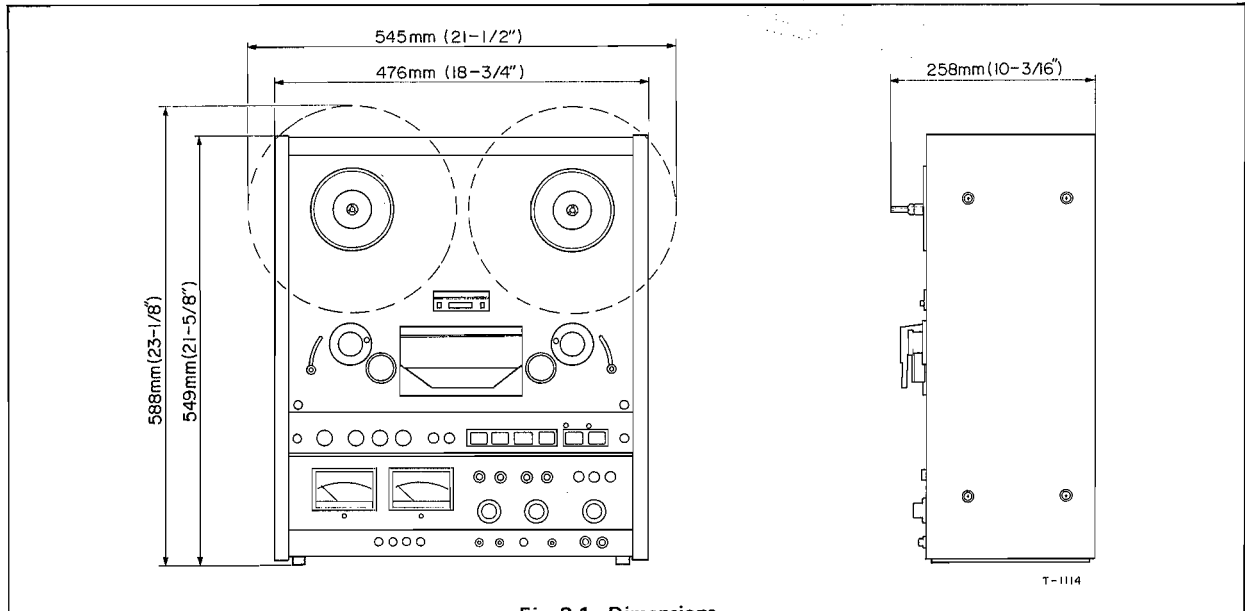

Fig. 2-1 Dimensions

3. TOOLS FOR TESTING AND MAINTENANCE

A minimum of the following tools and test instruments are required for measuring and adjusting to obtain optimum performance. Regular maintenance tools will be adequate for those not listed here. If any test instrument listed here is not available, a close equivalent can be used.

- SPRING SCALE 0-4 kg (0-8 lbs)
0-300 g (0-10 oz)
- FLUTTER METER Meguro Denpa Sokki K.K.,
Model MK-668C
- DIGITAL COUNTER Range; 0 Hz-100 kHz
- BANDPASS FILTER TEAC MODEL M-206A (1 kHz)
- VTVM (AC) Hewlett-Packard Co., Model 400E
- AF OSCILLATOR 10 Hz-100 kHz
- ATTENUATOR General purpose
- OSCILLOSCOPE General purpose
- BLANK TAPE TEAC YTT-8023, 8013 and 8003
- TEAC TEST TAPE YTT-1003 (7-1/2 ips), YTT-1002
(3-3/4 ips) for Playback Alignment test
- YTT-2003 (7-1/2 ips), YTT-2002
(3-3/4 ips) for Tape Speed
and Wow and Flutter test
- TEAC EMPTY REEL RE-702 (2.5" dia, hub)
RE-701 (4" dia, hub)
- TOOLS General
2 mm nut driver
Hex Head Allen Wrench
Plastic alignment tool
- Load resistor non inductive type 8 ohm/1 W
- DEMAGNETIZER TEAC E-3 or equivalent

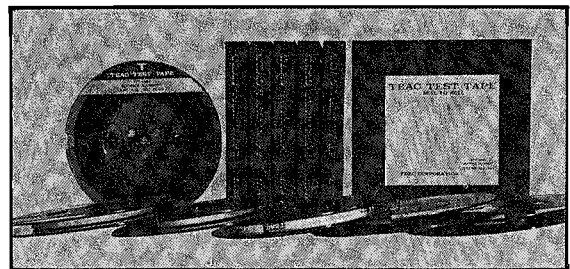

Fig. 3-1 TEAC Test Tape

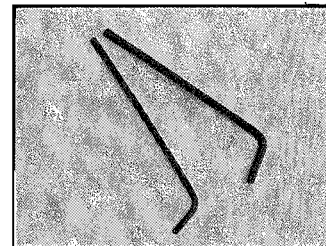

Fig. 3-2 Hex Head (Allen) wrench

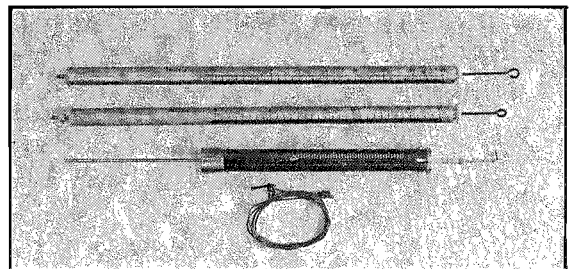

Fig. 3-3 Spring Scales

4. PARTIAL DIS-ASSEMBLY

4-1 OUTER CASE AND PANEL REMOVAL

Remove necessary panels as shown in the illustration.

Unplug the power cord before removing any panel or internal parts.

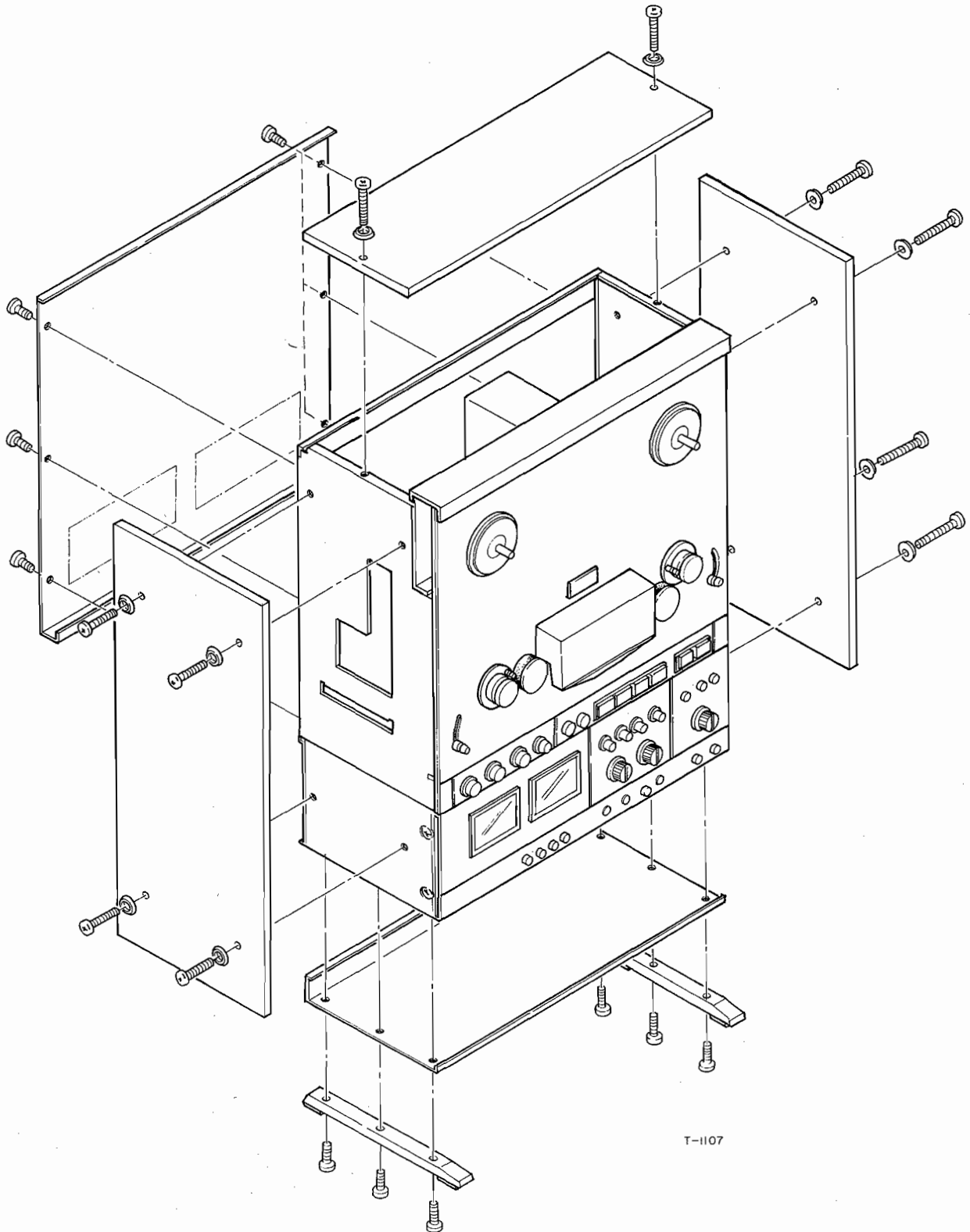

T-1107

Fig. 4-1 Outer Case and Panel Removal

4-2 CAPSTAN MOTOR, FLYWHEEL AND CAPSTAN ASS'Y REMOVAL

1. Unscrew (by hand) the capstan dust cap (H).
2. Remove 2 screws from capstan thrust angle (B) and remove it.
3. Remove flywheel (C) by loosening 2 hex head set screws and removing drive belt (D).
4. Remove capstan motor (A) by removing 3 screws.
5. Disconnect 3 wires to capstan motor from PC Board.

—CAPSTAN ASS'Y REMOVAL (E)—

6. Remove arm Support plate (F) and capstan ass'y (E) by removing 3 screws.

NOTE: When replacing parts make sure belt and capstan shaft are clean and free of oil. Clean these parts if necessary. Also make sure belt is installed properly as shown in the figure.

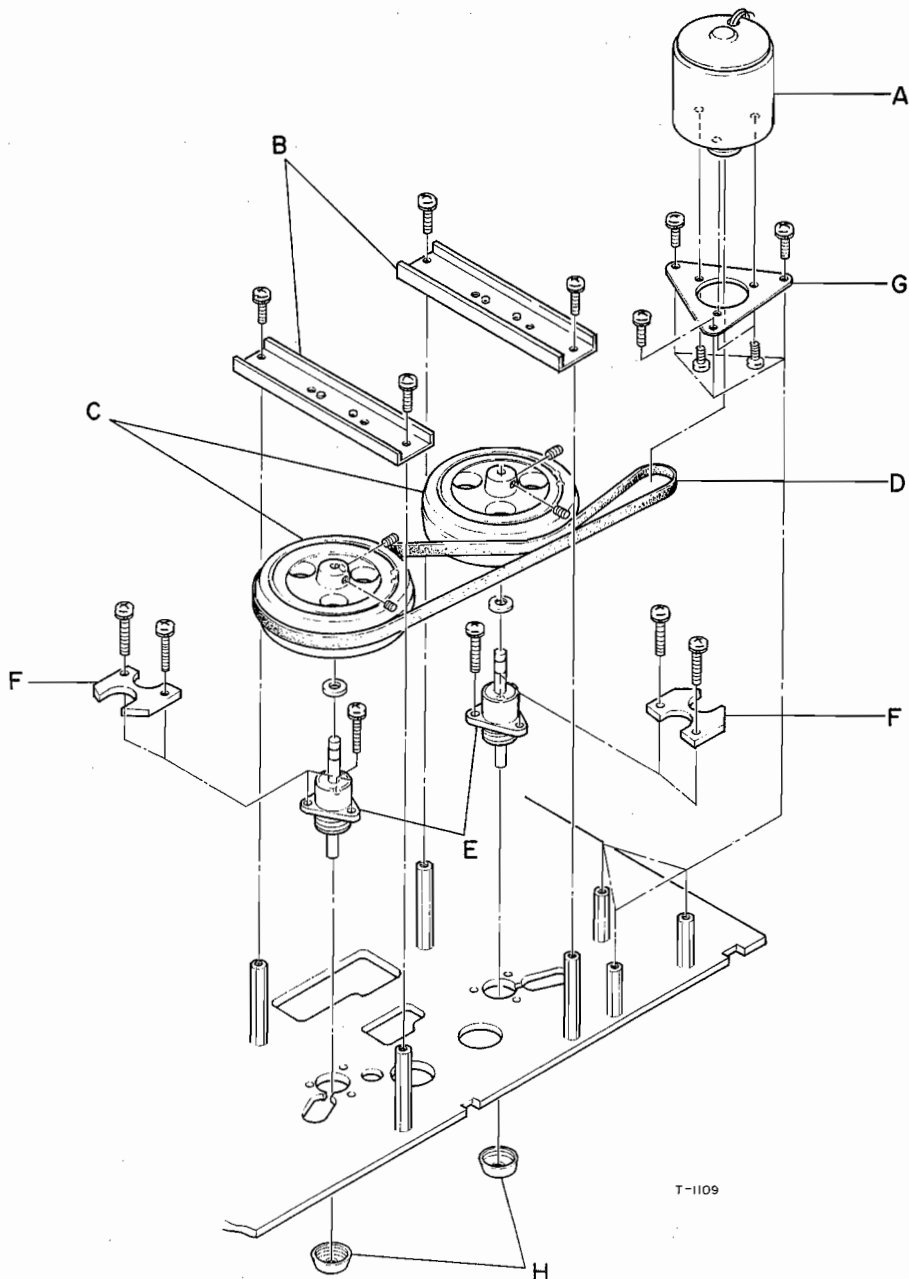

Fig. 4-2 Capstan Motor, Flywheel and Capstan Ass'y Removal

4-3 REEL MOTOR REMOVAL

1. Remove wire harness straps (X3) and P.C. Board Retainer (B) (1 screw).
2. Disconnect the 4 motor wires from terminals on P.C. Board and release wire harness straps.
3. Loosen 2 set screws (hex head) in brake drum (A) and 2 in the reel turntable ass'y (F) at front of the reel motor.

Lift off these parts.

4. Remove 4 screws securing the brake ass'y (D) to the motor.
Carefully lift off the brake ass'y (D).
Do not remove wires connected to the brake solenoid (C).
5. Remove 4 screws securing reel motor (E) to chassis through the front panel.

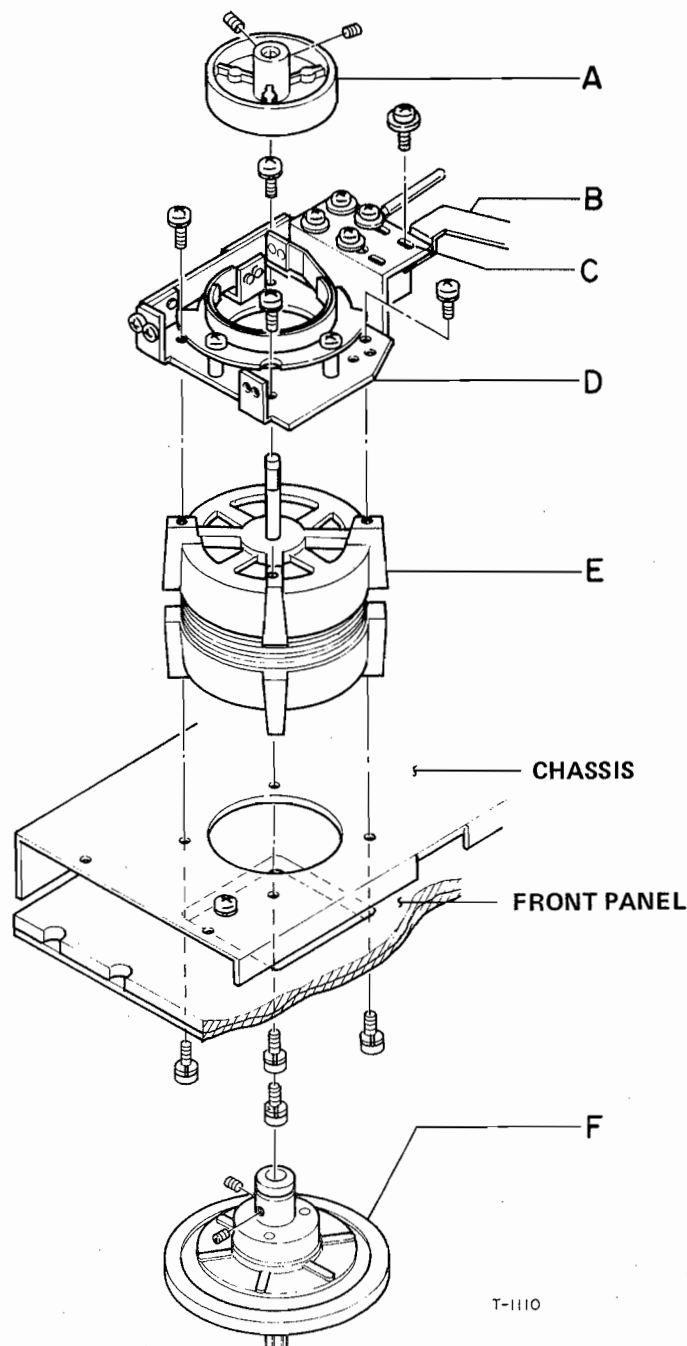

T-1110

Fig. 4-3 Reel Motor Removal

4-4 TENSION ARM REMOVAL

1. Loosen set screw in tension arm ass'y (F) and remove tension arm guide (D).
2. Disconnect one end of spring (H).
3. Loosen set screw in thrust boss (G) and remove thrust boss and washer.
Then remove tension arm ass'y (F).

—GUIDE ROLLER REMOVAL— (A)

4. Loosen set screw in roller bearing (E) and remove it and the washers.
5. Lift out guide roller ass'y (A). Watch for the washer.

—METAL HOLDER ASS'Y REMOVAL— (B)

7. Remove 1 screw from inside of front panel to right pole. When removing screw, roller base ass'y(C) will also be free, so remove it at the same time.

NOTE: Roller sheet (J) will remain attached to front panel.

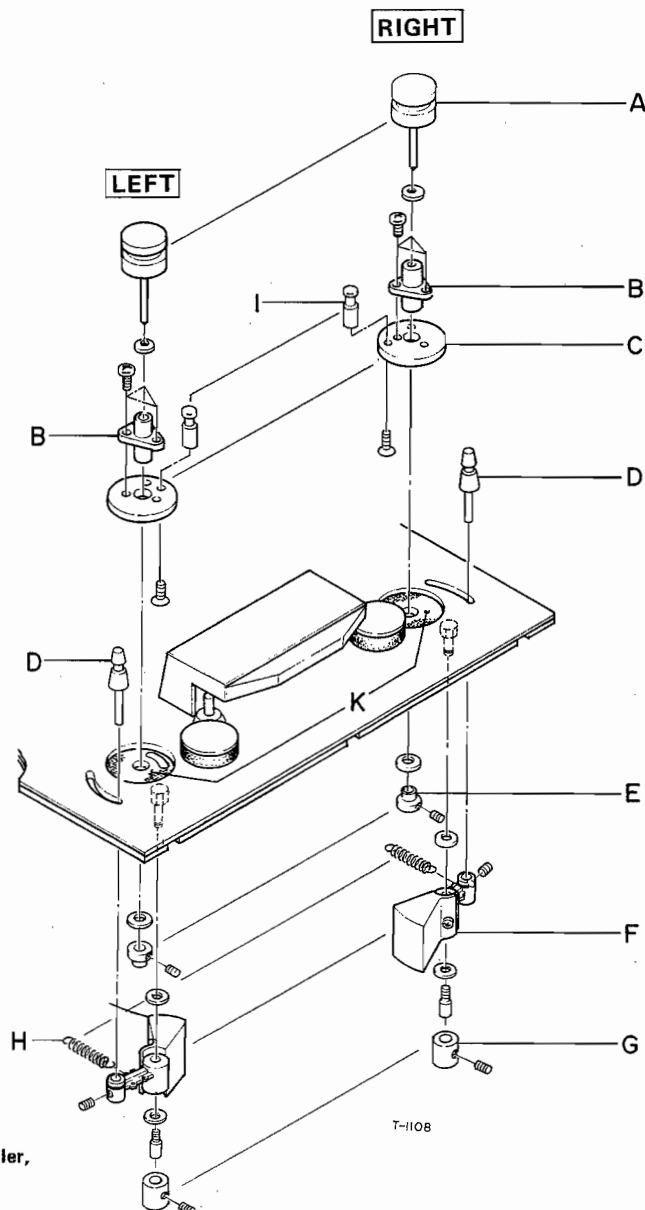

Fig. 4-4 Tension Arm, Guide Roller, Metal Holder Ass'y and Right Pole Removal

4-5 TRANSFORMER REMOVAL

1. Remove 4 screws from FUSE PCB (A) and move it back out of the way.
2. Remove 4 screws from transformer cover (B).
3. Disconnect 4 wires from transformer to voltage selector SW. (General Export Model)

Note location and color code of wires to voltage selector SW.

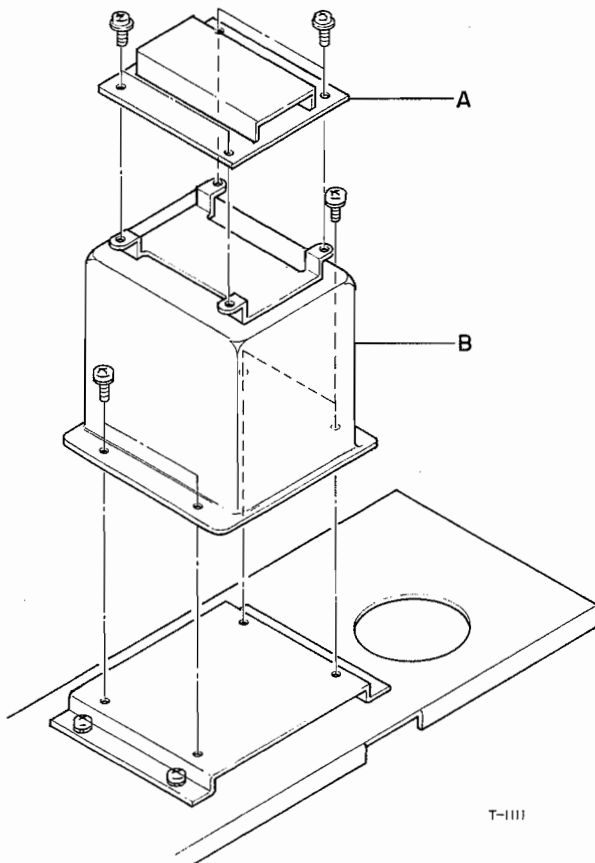

Fig. 4-5 Transformer Removal

4-6 HEAD ASSEMBLY REMOVAL

1. Remove the 2 screws in the top of the head cover and lift it off.
2. Remove 3 screws holding head base plate (with heads).
3. Remove 2 mounting nuts through access slot in head base plate and dis-connect head wires. See Fig. 6-4.

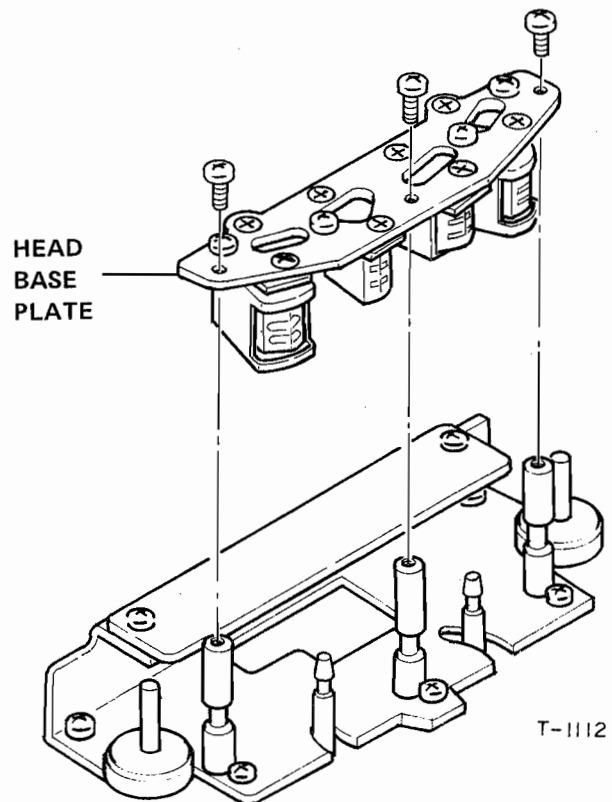

Fig. 4-6 Head Ass'y Removal

5. TAPE TRANSPORT PARTS LOCATION

— REAR VIEW —

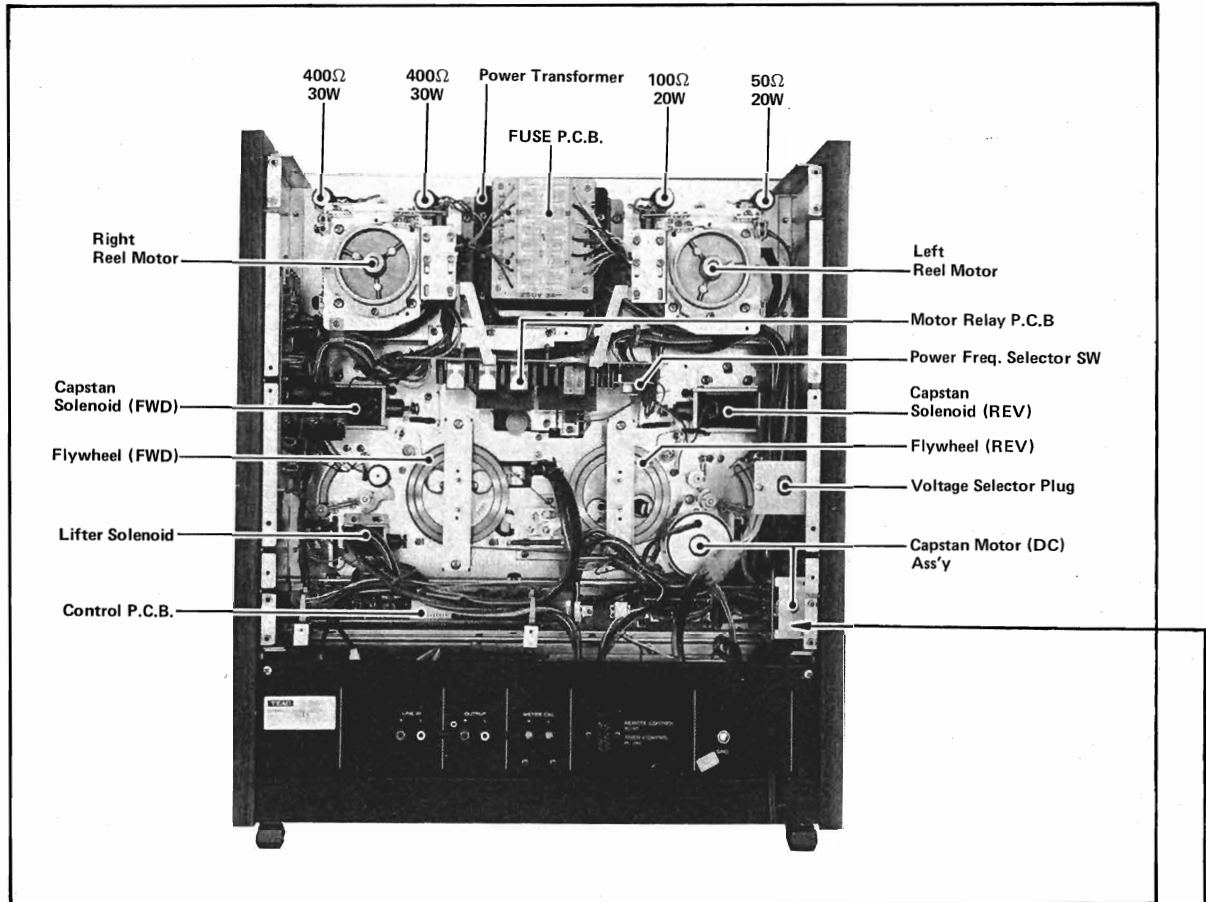
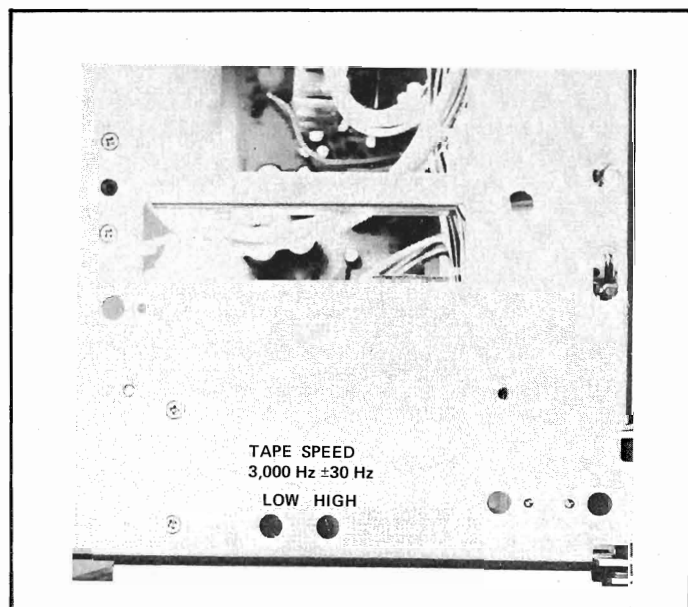

Fig. 5-1 Tape Transport Parts Location



6. HEAD REPLACEMENT AND ALIGNMENT

— MECHANICAL —

6-1 HEAD REPLACEMENT

To replace a single head a special 2 mm nut driver is required. Remove the 2 nuts (A) on the defective head through the access hole provided. This releases the head from the mounting plate. Note the position of the wires on the circuit board. Connect the new head in the same manner. Replace the nuts securing the new head to the plate. Perform head alignment before operation.

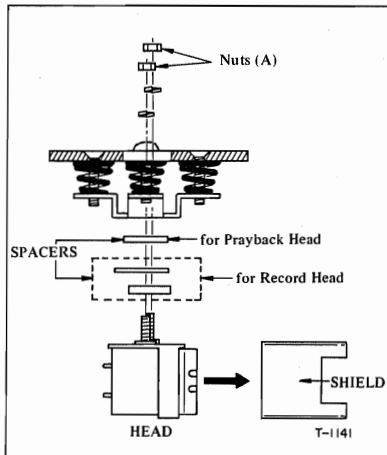

Fig. 6-1 Head Replacement

6-2 HEAD ADJ. SCREWS AND ALIGNMENT

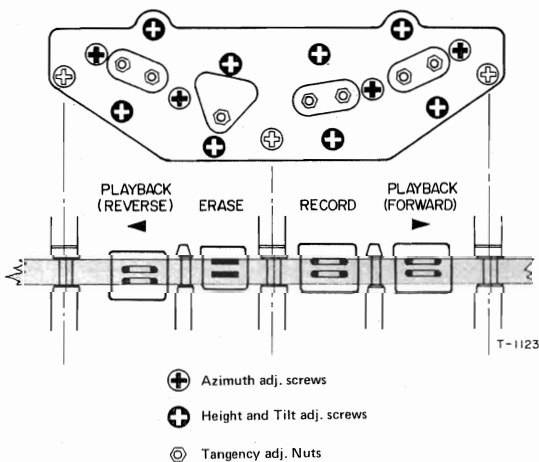

Fig. 6-2 Head Adjustment Screws and Alignment

6-3 VISUAL HEAD ALIGNMENT

Since the head alignment critically affects the frequency response on both playback and recording, the head alignment should be done carefully. The head can be adjusted in TILT, TANGENCY, HEIGHT and AZIMUTH.

For head alignment, perform the following coarse adjustments first. Then fine alignment should be accomplished electrically while playing back the Test Tape.

Coarse Adjustment:

Without Tape

TILT By Height and Tilt screws

This alignment is performed by viewing from the side without tape threaded.

Check that the head surface is parallel to the tape guide surface.

With Tape

TANGENCY By Head mounting nuts

Loosen the head mounting nuts. Adjust the head so that the vertical alignment of the head gap is perpendicular to the surface of the tape, then tighten the head mounting nuts.

HEIGHT By Height and Tilt screws

This alignment is checked visually by looking at the position of the head.

The head core for track-1 (inner core) should be even with the inner edge of the tape.

AZIMUTH By Azimuth adj. Screw

Adjust the azimuth adj. screw so that the gap of the head is perpendicular to the tape travel.

NOTE: After this coarse adjustment is made, the adj. screws and the Head mounting nuts should be realigned according to electrical head alignment paragraph which follows in this Service Manual.

6-4 MIS-ALIGNMENT OF THE HEADS

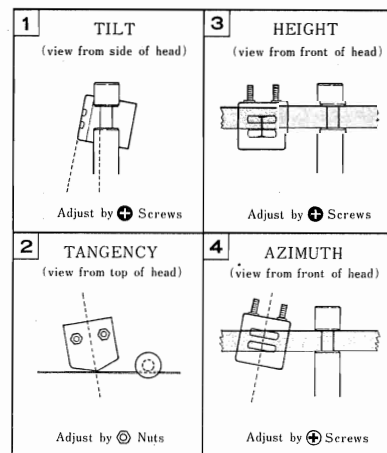

Fig. 6-3 Head Mis-Alignment — Examples —

- HEAD WIRING -

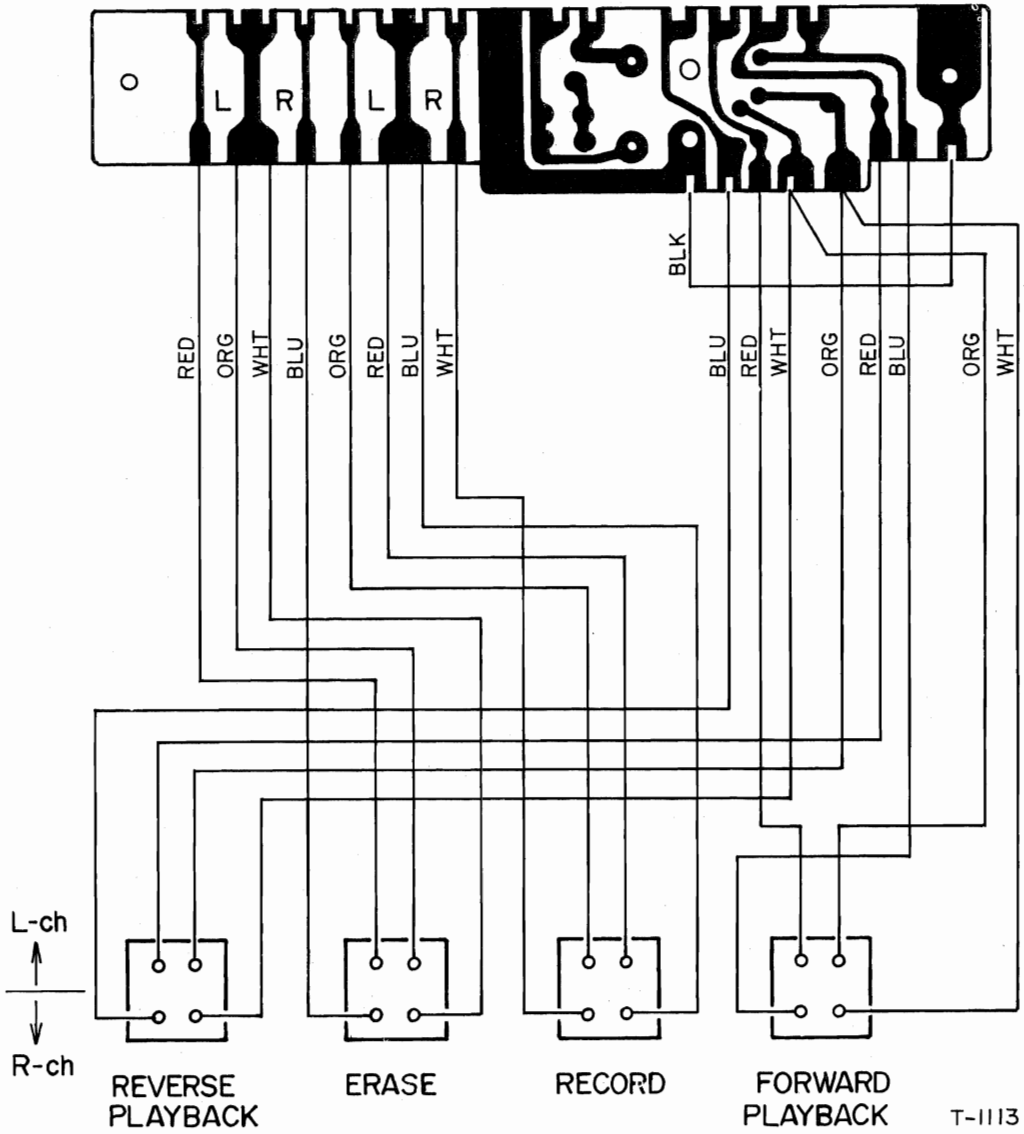

Fig. 6-4 Head wiring

7. MEASUREMENT AND ADJUSTMENT — MECHANICAL —

7-1 PINCH ROLLER PRESSURE CHECK

NOTE: Pinch roller pressure is supplied by the pinch roller spring arms and it is most important that the solenoid plungers be fully bottomed before taking pressure measurements.

1. Load tape or block the shut-off arm in the ON position.
2. Attach a suitable spring scale to the right side pinch roller shaft.
3. Place the deck in the Play (▶) mode, and holding the spring scale as illustrated, slowly draw it away from the pinch roller.
4. Do not allow the spring to rub against the pinch roller.
5. Note the reading on the spring scale at the instant the pinch roller stops rotating.
6. The scale should indicated 2.1 to 2.3 kg (4.6 to 5.0 lbs)
7. If adjustment is necessary, loosen the 3 screws on the capstan solenoid and position the solenoid for optimum pressure.
8. Adjust solenoid-limit position so that the gap between capstan shaft and pinch roller is approx. 7mm when solenoid is not actuated. Also make sure pinch roller shaft does not contact Spring Arm (B). Limit is adjusted by loosening the mounting screw (A), then sliding limit until proper position is obtained.
9. Repeat this procedure for the reverse play (◀) operation measuring the left side pinch roller pressure.

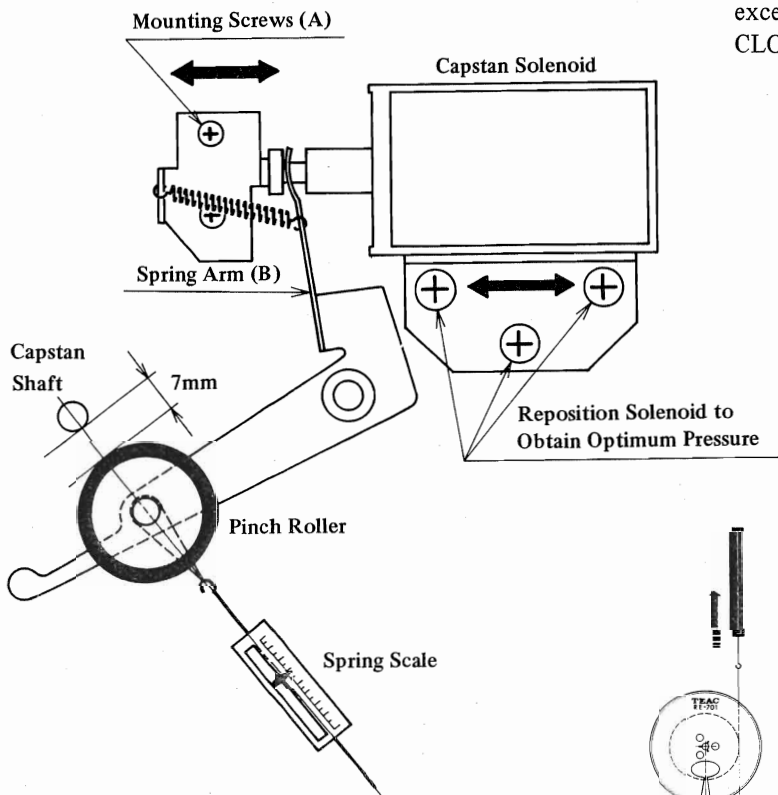

Fig. 7-1 Pressure Measurement and Adj. Location

7-2 BRAKE TORQUE MEASUREMENT

NOTE: The brake torque is actuated mechanically.

Torque is set by the variable Leaf Spring Force. While making these measurements and adjustments, be careful not to bend the brake bands. Brake shoes should be cleaned only when absolutely necessary. If cleaning is required; use TEAC cleaner TZ-261A. After cleaning, operate the brakes by depressing the play and STOP buttons several times to completely dry out the brakes before performing the following procedure. Brake torque measurement is made with Power OFF.

1. Place an empty large hub reel on the left reel table, and fasten one end of a 30" length of string to the reel anchor.
2. Wind several turns of string counter clockwise around the hub and attach a suitable spring scale to the free end of the string.
3. Pull on the spring scale and take a reading only when the reel is in steady motion since the force required to overcome static friction will produce a false, excessively high initial reading.
4. The reading should be 1600 to 2000 g-cm (22.4 to 28.0 oz inch).
5. If adjustment is required, loosen the 3 screws shown and position the brake for optimum pressure.
6. The adjustment of the right brake is the same, with the exception that rotations are clockwise. (wind string CLOCKWISE around reel hub)

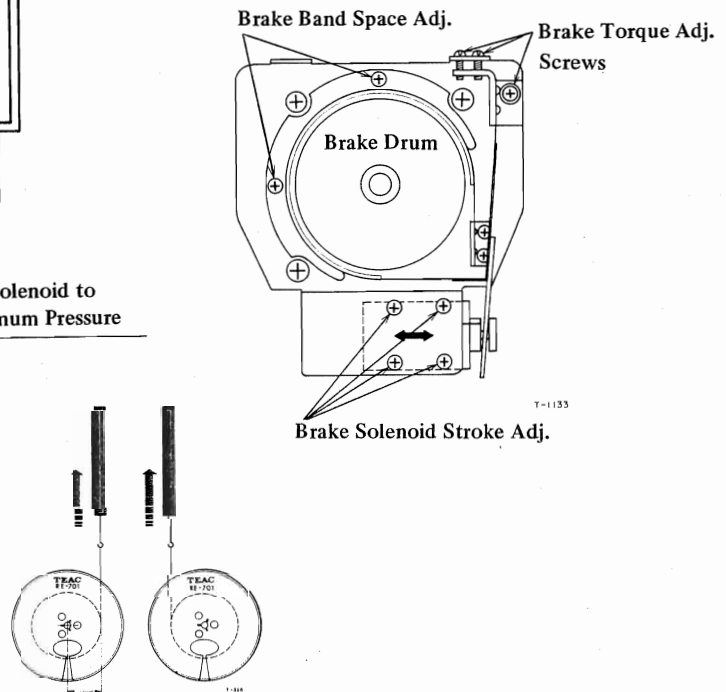

Fig. 7-2 Torque Measurement and Adj. Location

TORQUE MEASUREMENT PROCEDURE

NOTE: The following torque measurements should be made with a spring scale that is calibrated to read Torque in gram-cm. for a 7" reel with a small reel hub. If the spring scale you are using is calibrated to read Force or Weight in grams the Torque must be calculated using the Formula:

$$\text{Torque (in gm}\cdot\text{cm or oz}\cdot\text{in)} = \text{Weight or Force (in gr. or oz.)} \times \text{radius of hub (in cm or inches)}$$

If you are using a reel with other than the standard 2.5" or 6.0 cm (approx.) diameter hub, the Torque must be calculated using the same formula and substituting the actual radius and Weight or Force reading.

All Torque and Tension measurements must be made with the automatic shut-off switch (right or left tension arm) held in the ON position.

Brake Torque Measurement should be made using large hub reel with a hub diameter of 4" or 10.2 cm.

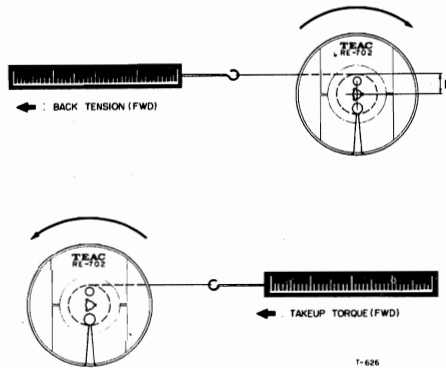

Fig. 7-3 Torque Measurement

7-3 TAKE-UP TORQUE

1. Place the empty reel on the right reel table and attach spring scale.
2. Place the deck in the Play mode.
3. Allow the rotation of the reel to slowly draw the scale toward the hub.
4. Hold the spring scale with enough force to allow a steady reading.
5. Repeat the procedure for the Reverse (◀) Play.
6. **The reading or calculated value should be approx.:**

	REEL SW	TAKE UP VALUES
FWD	LARGE	680 to 720 g-cm (9.5 to 10 oz-inch)
	SMALL	350 to 450 g-cm (5.0 to 6.3 oz-inch)
REV	LARGE	650 to 750 g-cm (9.0 to 11 oz-inch)
	SMALL	350 to 450 g-cm (5.0 to 6.3 oz-inch)

7-4 BACK TENSION

1. Place an empty 7" reel with small hub on the left reel table and fasten one end of a 30" length of string to the reel anchor.
2. Wind several turns of string counter-clockwise around the hub. Attach spring scale to string.
3. Place the deck in the Play mode.
4. Pull the scale away from the reel against the motor torque with a steady, smooth motion.
5. Note the scale reading while it is in steady motion. (The string must not rub the reel flanges)
6. Repeat the procedure for the Reverse (◀) Play.
7. **The reading or calculated value should be approx.:**

	REEL SW	BACK TENSION VALUES
FWD	LARGE	380 to 420 g-cm (5.3 to 6.0 oz-inch)
	SMALL	230 to 270 g-cm (3.2 to 4.0 oz-inch)
REV	LARGE	350 to 450 g-cm (5.0 to 6.3 oz-inch)
	SMALL	200 to 300 g-cm (3.0 to 4.0 oz-inch)

Adjustment Location

If necessary, adjust slider of the resistors until you have the correct scale reading for optimum torque. Refer to adj. location below.

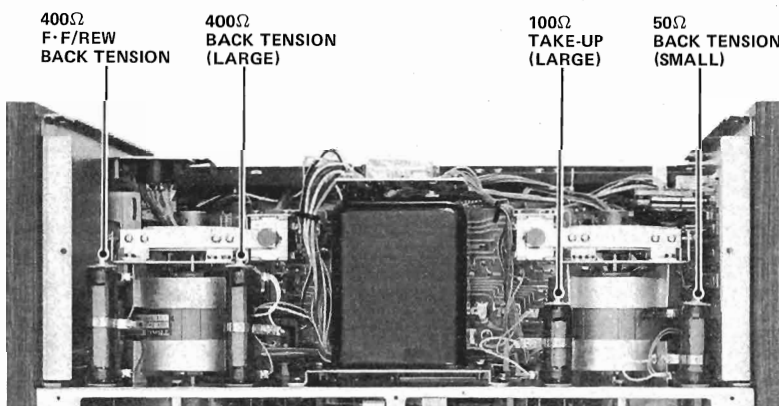

Fig. 7-4 Resistors Adj. Location

7-5 FAST FORWARD AND REWIND TORQUE SPECIFICATION

2000 g-cm (28 oz-inch), or more at F.F.
2000 g-cm (28 oz-inch), or more at REW

7-6 TENSION GUIDE HEIGHT ADJUSTMENT

1. Check that there is a clearance of approx. 1 mm between tension arm and surface of the tape deck face plate.
2. Thread Tape on the deck and run it in both directions to check that tape moves in the center of the guide.
3. If adjustment is necessary, loosen the screw and move tension arm. Then tighten screw and repeat step 1 and 2.

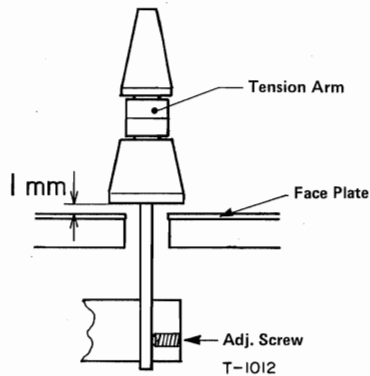

Fig. 7-5 Tension Guide Height Adj.

7-7 SENSING ASS'Y POSITION ADJUSTMENT

1. Check that the brush of the sensing ass'y lightly contacts the guide bearing.

CAUTION: If the brush contacts the guide bearing too firmly, the guide roller will not rotate.

2. Check that Auto Reverse playback can be initiated using sensing foil affixed to the tape.

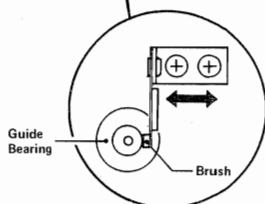
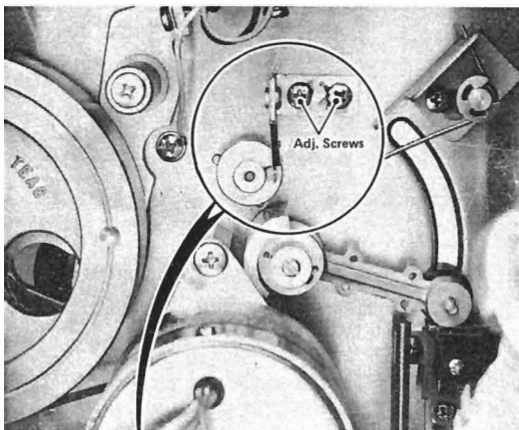

T-1118

Fig. 7-6 Sensing Ass'y Position Adj.

7-8 MAGNETIC RESISTANCE ELEMENT (SENDER ASS'Y) POSITION ADJ.

1. Adjust Screws (A) for a space (B) of approx. 1mm.
2. Check that there is no delay time when changing from F.F. (or REW) to Play mode.

Location; On Left side when viewed from the rear.

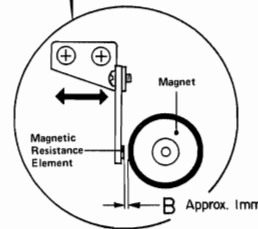
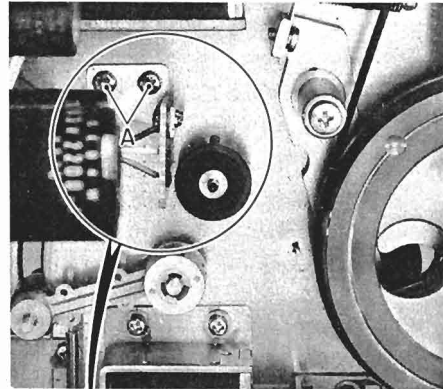
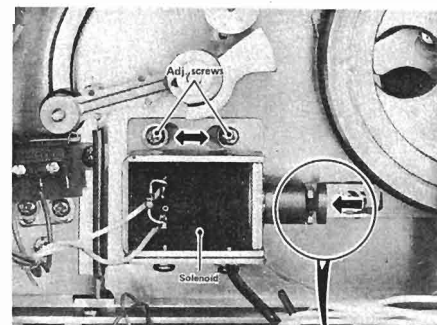

Fig. 7-7 Magnetic Resistance Element (Sender Ass'y) Position Adj.

7-9 LIFTER SOLENOID ADJUSTMENT

1. Make sure Power is turned off.
2. Depress the solenoid plunger until it is fully bottomed in the solenoid and check that there is no clearance between the lifter connecting lever and the solenoid plunger. See illustration (A).



T-1119

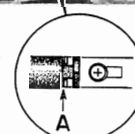

Fig. 7-8 Lifter Solenoid Adj.

7-10 TAPE SPEED

The tape speed should be measured using TEAC flutter free tape, Model YTT-2003 (7-1/2 ips), YTT-2002 (3-3/4 ips). These tapes contain a highly accurate 3,000 Hz tone. Connect a digital frequency counter to either line OUTPUT jack. The indicated frequency should be 3,000 Hz \pm 30 Hz for both speeds and both directions. If necessary, adjust Tape speed adjusters on the capstan servo P.C.B.d. See Fig. 5-1 on page 11 PARTS LOCATION Section.

7-11 WOW AND FLUTTER CHECK

NOTE: Before performing this measurement, clean the head and Tape run guides, also check pinch roller pressure, etc.

Use new Test Tape if possible for following adjustments.

Values obtained with different standards of equipment cannot be compared.

PLAYBACK

1. Connect Test equipment to the deck as shown in Fig. 7-9 (Except oscillator).
2. Load TEAC YTT-2003 (for HIGH, 7-1/2 ips) or YTT-2002 (for LOW, 3-3/4 ips) and playback tape.
3. Read the indication on the Wow and Flutter meter.
4. The Wow and Flutter should be

	HIGH (7-1/2 ips)	LOW (3-3/4 ips)
WRMS	0.08% or less	0.10% or less
RMS	0.10% or less	0.20% or less

OVERALL

1. Connect Test equipment to the deck as shown in Fig. 7-9
2. Load TEAC YTT-8003 Test Tape (blank tape) on the deck and Record a 3,000 Hz input signal.
3. Rewind and playback the recorded signal.
4. The reading on the Meter should be
 - 0.20% (RMS) for 7-1/2 ips
 - 0.25% (RMS) for 3-3/4 ips

NOTE: These figures apply to any tape position (such as full take-up reel, full supply reel or about mid-point).

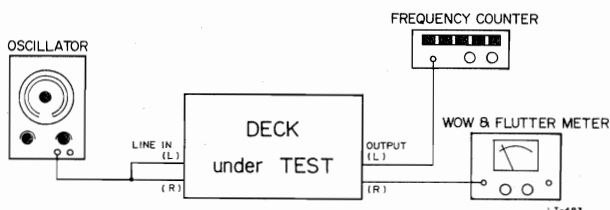

Fig. 7-9 Test Connections for Wow/Flutter and Tape Speed Test

7-12 VOLTAGE AND FREQUENCY CONVERSION (Export Model only)

This deck is adjusted to operate on an electric power source of the voltage and frequency specified on the reel tag and packing carton. If it is necessary to change the frequency or voltage requirements of this deck to match your area, use the following procedures.

Always Disconnect Power Line Cord before making these changes.

Frequency Conversion:

1. Remove the right side wood panel (4 screws), then the rear/top metal panel (6 screws).
2. Set the power frequency selector slide switch to the 50 or 60 position to match the power line frequency in your area. (See Location below).

NOTE: This deck uses a DC Servo controlled capstan motor so it is not necessary to change the capstan drive belt.

Voltage Conversion:

The deck may be set for 100, 117, 220 or 240 volts. To change the voltage, unscrew, the voltage selector plug. Pull out the plug and reinsert it so the desired voltage shows in the cutout. (See Location below).

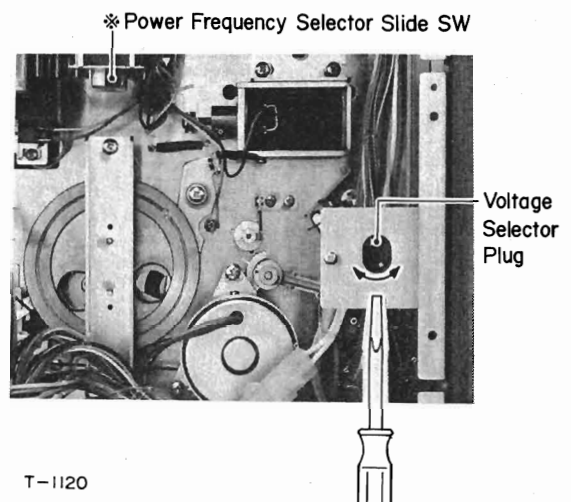

T-1120

Fig. 7-10 Voltage and Frequency Conversion Locations

8. MEASUREMENT AND ADJUSTMENT — ELECTRICAL —

- Before performing maintenance on this deck, thoroughly clean and demagnetize the entire Tape path, TEAC maintenance equipment to be used:
 TEAC TZ-261 A/B for cleaning
 TEAC E-3 or equivalent for demagnetizing
- Service Data were determined using TEAC YTT Series Test Tape.
- The deck must be matched to the voltage and frequency of your locality.
- Most amplifier checks and adjustments can be made from the bottom with the (bottom) metal panel removed.
- The procedures for checks and adjustments are normally done for the left and right channels and at both speeds. The adjustment locations such as R263/264 indicate left channel/right channel adjustments. Reverse playback should also be checked where indicated.

8-1 ADJUSTMENT LOCATIONS AND ADJUSTMENT POINTS

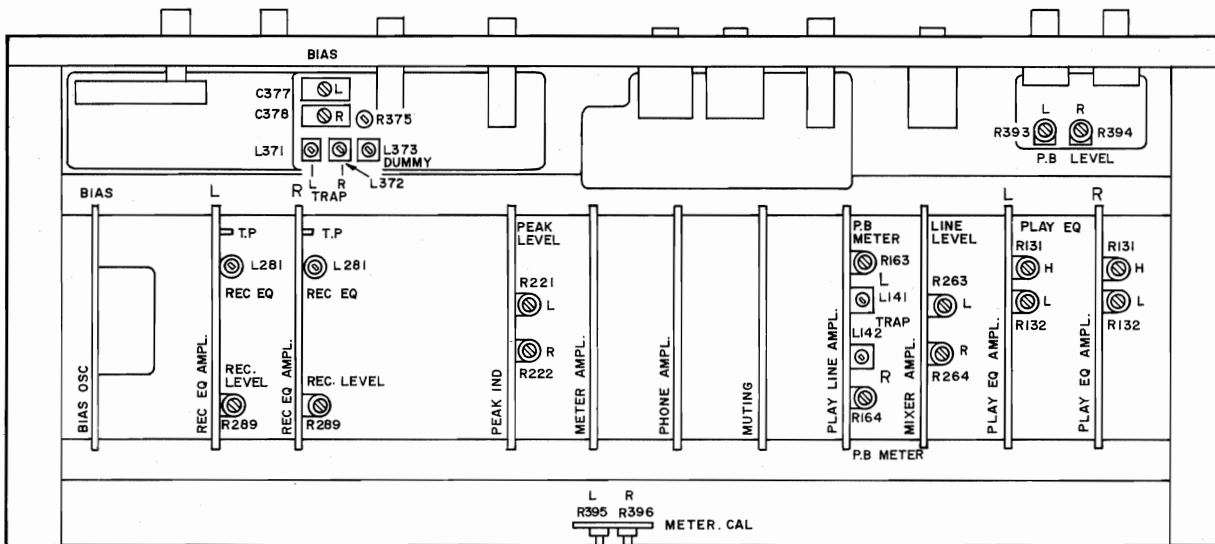

T-1115

Fig. 8-1 Adjustment Locations and Adjustment Points

8-2 ADJUSTMENT SEQUENCE CHART

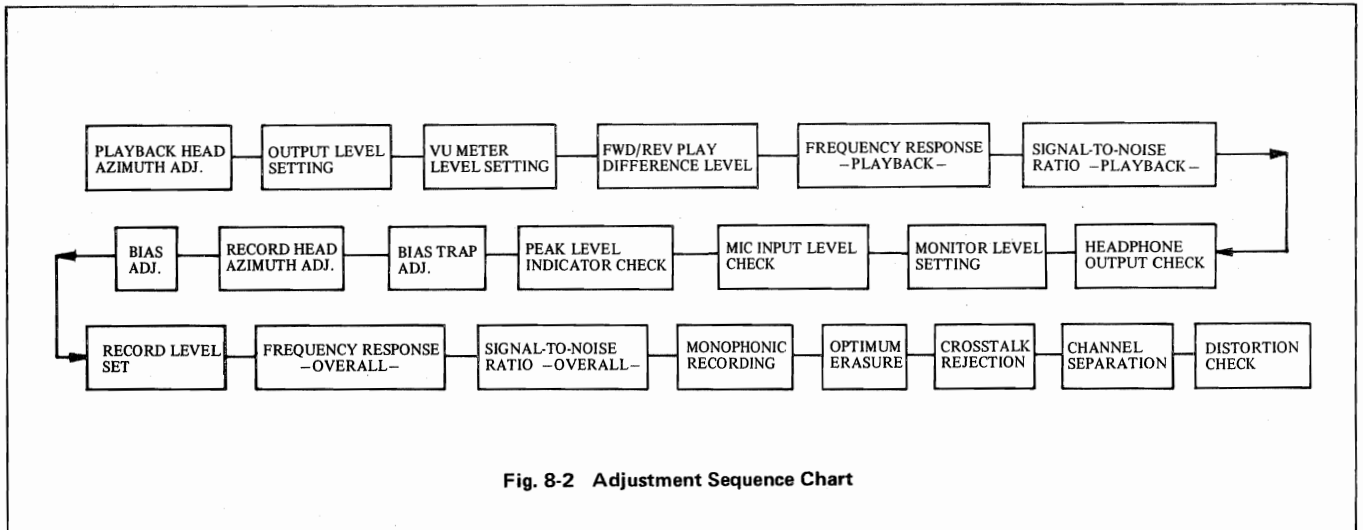

Fig. 8-2 Adjustment Sequence Chart

PLAYBACK PERFORMANCE

8-3 PLAYBACK HEAD AZIMUTH ADJ.

NOTE: Before proceeding with the following head alignments be sure that heads have been properly mounted as to HEIGHT, TILT and TANGENCY. See page 12.

MONITOR SW TAPE CAL
 SPEED Selector SW HIGH (7-1/2 ips)
 REEL Size Selector SW . . SMALL
 TRIM controls (L and R) . Click position (center)
 OUTPUT Level Control . . 0 VU

– Fine Adjustment–

1. Connect a VTVM to the OUTPUT jacks.
2. Remove the Head Housing by removing 2 screws.
3. Thread the TEAC YTT-1003 Test Tape on the deck.
4. Play (▶) the 16 kHz/–10 dB test tone in section 2 of the test tape.
5. Slowly rotate the Azimuth screw until maximum signal is read on the VTVM.
6. Connect an oscilloscope to the OUTPUT jacks.
7. Adjust the azimuth screw (if necessary) until the oscilloscope shows that the signals are less than 45° out of phase for 18 kHz signal. Check this using the 18 kHz signal from the frequency response section of the test tape.
8. Secure the screw with a drop of locking paint.
9. Depress the (◀) button and turn the azimuth adjusting screw for the reverse playback head (see Fig. 6-2) for maximum indication on the VTVM. Repeat steps 6 to 8 above for reverse playback head.

8-4 OUTPUT LEVEL SETTING

– SPECIFIED OUTPUT LEVEL –

10. Play the 400 Hz/0 dB tone in section 1 of the YTT-1003 Test Tape.
11. Set the reference mark of the OUTPUT Level Control to the 8 (0 VU) position.
12. Adjust P.B LEVEL R393/394 for –5 dB (435 mV) at OUTPUT jacks.

– MAX. OUTPUT LEVEL –

13. Turn the OUTPUT Level Control fully clockwise (max.) and check for +1 dB ±2 dB at OUTPUT jacks.
14. Reduce OUTPUT Level Control until –5 dB (435 mV) is obtained on the output VTVM.

NOTE: This is the Specified Output level setting. Do not disturb this setting until the remaining adjustments have been completed.

The minimum TRIM controls limits are $+3$ dB from click position.

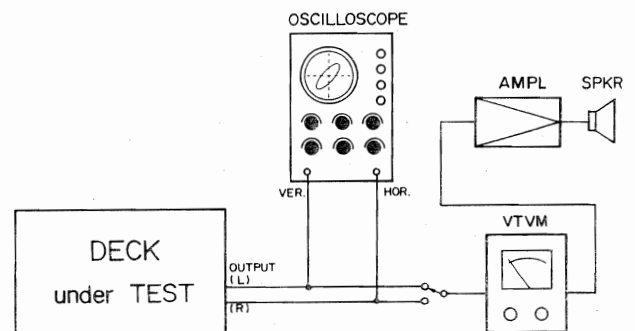

T-389-2

Fig. 8-3 Head Alignment Fine Adjustment Set-up and Test Connections (PLAYBACK)

8-5 VU METER LEVEL SETTING

15. Adjust METER CAL R395/396 (on rear panel) for 0 VU reading on VU Meters.

MONITOR SW TAPE OUT

16. Adjust P.B.METER R163/164 for 0 VU reading on VU Meters.

8-6 FWD and REV PLAY DIFFERENCE LEVEL

17. With the controls set as described in item 8-4, Check that the difference in the playback level between Forward play and Reverse play is within the following limits:
±2 dB or less

Also check that the difference between channels is within 2 dB or less.

8-7 FREQUENCY RESPONSE – PLAYBACK–

18. Thread TEAC YTT-1003 on the deck.
19. Play Tape and compare reading on VTVM with the response limits given in Fig. 8-4 (A).
20. If adjustment is required, adjust PLAY EQ H R131 for High speed.
21. Thread the TEAC YTT-1002 on the deck and set the SPEED switch to LOW.
22. Play the tape and compare the readings on the VTVM with the response limits given in Fig. 8-4 (B).
23. If adjustment is required, adjust PLAY EQ L R132 for LOW speed.
24. Depress Reverse Play (◀) button and check for suitable output from both channels. If necessary adjust height and azimuth adjustment screws (see Fig. 6-2) of Reverse Playback head for best output.

NOTE: Check azimuth for LOW speed at 10 kHz reference frequency.

If the frequency response does not meet specified response limits, especially at the high-end of the spectrum, head should be checked for accumulated dirt or oxides. If clean, head azimuth must be readjusted.

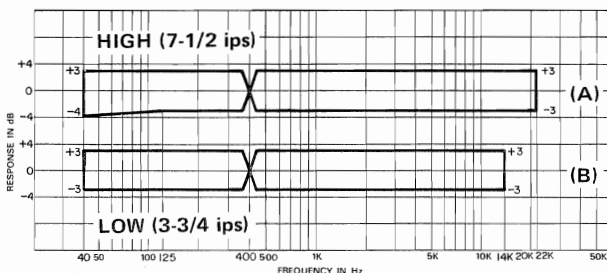

Fig. 8-4 Frequency Response – PLAYBACK –

8-8 SIGNAL-TO-NOISE RATIO – PLAYBACK –

1. OUTPUT Level Control should be at the Specified Output level setting.
2. Remove Test Tape from deck. Hold Shut-off arm, left or right, to ON position.
3. Depress the Play (▶) button.
4. The VTVM connected to the OUTPUT jacks should indicate listed value below.

–56 dB, or more HIGH (7-1/2 ips)
–53 dB, or more LOW (3-3/4 ips)

NOTE: This corresponds to Signal-to-Noise Ratio of 51 dB (for HIGH) and 48 dB (for LOW); Difference between residual noise of –56 dB/–53 dB and specified output level of –5 dB.

8-9 HEADPHONE OUTPUT CHECK

1. Connect an 8 ohm non-inductive resistor across the headphone (PHONES) jack.
2. Connect VTVM across the resistor. While playing back operating level (400 Hz) on Test Tape VTVM should indicate – 19 dB ±2 dB (69 mV ~ 109 mV).

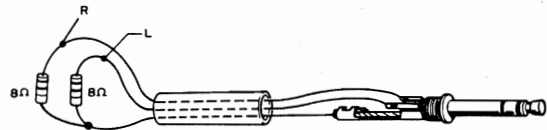

Fig. 8-5 Test Connections for Headphone output check

MONITOR PERFORMANCE

**8-10 MONITOR LEVEL SETTING
(LINE INPUT)**

MONITOR SW SOURCE
LINE Level Controls . . MAX.
MIC Level Controls . . . MIN.

1. Apply a 400 Hz/-22 dB (61.5 mV) signal from AF oscillator to LINE IN jacks.
2. Adjust LINE LEVEL R263/264 for -5 dB (435 mV) at the OUTPUT jacks.
3. Change the Input Signal to -12 dB (194 mV).
4. Adjust LINE Level Controls (small knobs) L and R for -5 dB (435 mV) at the OUTPUT jacks (VU Meters will read 0 VU ±0.5 VU). This is the specified setting of the LINE Level Controls. Do not move this setting until the adjustment procedure is finished.

8-11 MIC INPUT LEVEL CHECK

MIC ATT (dB) 0
MIC Level controls . . . MAX.
LINE Level controls . . . MIN.

5. Apply a 400 Hz signal at -70 dB (0.244 mV) to the MIC Input jacks. (on front panel).
6. Check for -5 dB ±2 dB (345 mV ~ 548 mV) at OUTPUT jacks.
7. Change the Input signal to -60 dB Level (0.774 mV).
8. Adjust MIC Level controls (Small Knobs) L and R for -5 dB (435 mV) at the OUTPUT jacks.

MIC ATT (dB) 20

9. Change the Input signal to -40 dB (7.74 mV).
10. Check for -5 dB ±2 dB (345 mV ~ 548 mV) at OUTPUT jacks.
11. Return MIC Level controls fully counter clockwise (min.) to prevent noise insertion during following steps.

8-12 PEAK LEVEL INDICATOR CHECK

12. With the controls set as described in 8-10, check that the PEAK level indicator lights at full intensity at the following levels:

Tape Speed	Full Intensity Level
HIGH	+ 10 dB ±1 dB
LOW	+ 8 dB ±1 dB

If adjustment is necessary, adjust PEAK level R221/222. Also check that the PEAK Level lamp goes out when the level is +9 dB (at HIGH) and at +7 dB (at LOW).

CAUTION: Apply this high level signal for only a few seconds to avoid damaging the VU meters.

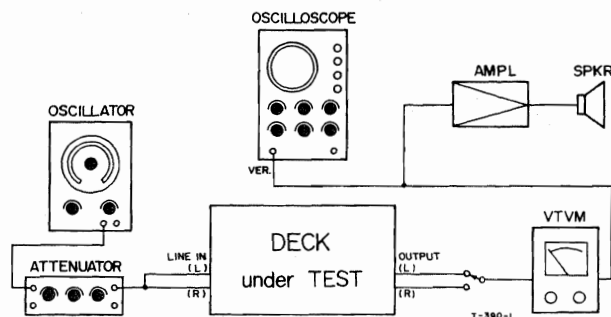

Fig. 8-6 Test Connections for Monitor Check

8-13 BIAS TRAP ADJUSTMENT

MONITOR SW SOURCE
 RECORD MODE SW. (L, R) . . ON

1. Remove all Input signals.
2. Thread Blank Test Tape on the deck and depress RECORD and PAUSE button.
3. Connect a VTVM or oscilloscope to Test Point and ground. See Fig. 8-7.
4. Adjust TRAP L371 (L-ch) and L372 (R-ch) for minimum reading on VTVM or scope.
 Use Plastic alignment tool.

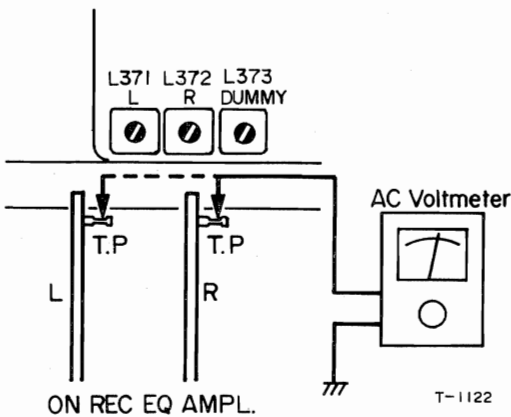

Fig. 8-7 Bias Trap Test Point

MONITOR SW TAPE OUT

5. Adjust TRAP L141 (L-ch) and L142 (R-ch) for minimum reading at OUTPUT jacks.
 Spec. -45 dB or less with OUTPUT Level Control at 0 VU position.

8-14 RECORD HEAD AZIMUTH ADJ.

NOTE: The effect of turning the azimuth screw will register on the VTVM.
 A slight delay will be noticed. Therefore, the screw must be rotated slightly with a pause to see the effect.

—Fine Adjustment—

6. Connect a VTVM to the OUTPUT jack and an AF oscillator to the LINE IN jacks.
 Set the oscillator to 10 kHz at -22 dB (61.5 mV).
7. Begin recording (Depress RECORD and Play buttons).
8. While recording and monitoring the tape play back adjust the azimuth screw for maximum reading on the VTVM.

NOTE: It is absolutely essential to accomplish the above adjustment before performing the following adj. to avoid phase errors greater than 45°.

9. Sweep the oscillator frequency from 40 Hz to 16 kHz (for HIGH), 40 Hz to 10 kHz (for LOW) and check that phase difference between channels is 45° or less.
10. Secure the screw with insulating locking paint.

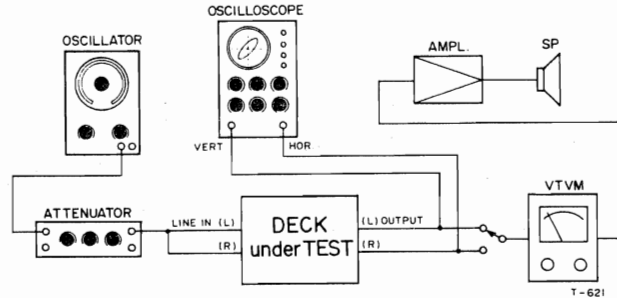

Fig. 8-8 Test Connection for Recording Check

8-15 BIAS ADJUSTMENT (BIAS #1)

SPEED Selector SW . . LOW (3-3/4 ips)
 BIAS SW 1
 EQ SW 1

Be sure the Bias Trap has been adjusted per section 8-13 before proceeding.

11. Apply 7 kHz signal at -22 dB (61.5mV) to the LINE IN jacks.
12. While recording on the YTT-8013 Test Tape, adjust Trimmer Condenser BIAS C377/378 for peak reading on the VTVM, then turn the Trimmer Condenser clockwise until decrease of 2 dB "Over-bias" from the peak is obtained.

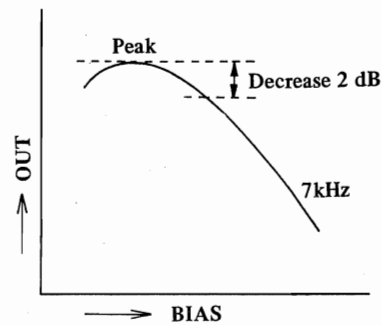

Fig. 8-9 Bias Limits Chart

8-16 RECORD LEVEL SET

SPEED Selector SW . . HIGH (7-1/2 ips)

13. Apply 400 Hz signal at -12 dB (194 mV) to the LINE IN jacks.
 Be sure the Line and Output Level Controls are still at their specified positions (see 8-4 and 8-10).
14. Begin recording.
15. Adjust REC LEVEL R289 for -5 dB (435 mV) at OUTPUT jacks.

8-17 FREQUENCY RESPONSE –OVERALL–

NOTE: To avoid saturation of the tape these checks should be made at least 10 dB below (for HIGH Speed) and 20 dB below (for LOW Speed) the specified input level.
Any Bias signal feeding into the test equipment should be filtered out by adjusting the external Bias Trap.

16. Apply signal swept from 40 Hz to 20 kHz, -22 dB (61.5 mV) to the LINE IN jacks and record on a blank TEAC YTT-8013 Test Tape.
17. During recording, monitor the Tape signal and adjust equalization REC EQ L281 for readings within the Response Limits charts. See Fig. 8-10 (A) below.

SPEED Selector SW . . . LOW(3-3/4 ips)

18. Apply signal swept from 40 Hz to 16 kHz, -32 dB (19.4 mV) and while monitoring the off-the-tape signal check for readings within the Response Limits charts. See Fig. 8-10 (B) below.

22. Repeat the above procedure using YTT-8023 blank Test Tape.

BIAS SW 2
EQ SW 2

Check the HIGH and LOW speed Frequency Response, are within the Response limits charts. See Fig. 8-11 (C), (D) below.

NOTE: If the response is not uniform, the head should be cleaned of accumulated oxide and dirt. Then repeat the Bias adjustment procedure.

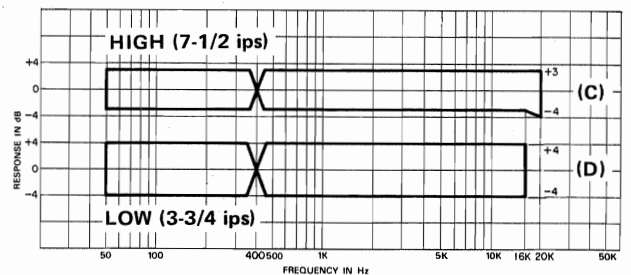

Frequency Response – OVERALL – 2

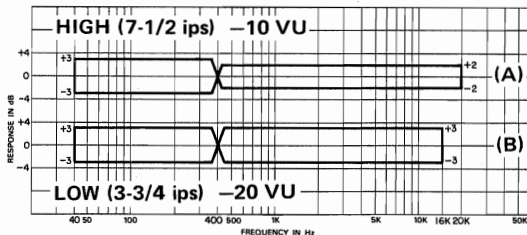

Fig. 8-10 Frequency Response – OVERALL – 1

–BIAS #2 ADJUSTMENT–

SPEED Selector SW . . HIGH (7-1/2ips)
BIAS SW 2
EQ SW 1

19. Apply signals swept from 40 Hz to 20 kHz -22 dB (61.5 mV) to the LINE IN jacks while recording on a blank TEAC YTT-8003 Test Tape.
20. Adjust equalization R375 for readings within the response limits charts. See Fig. 8-10 (A) above.
21. Repeat the above procedure for LOW, using a signal swept from 40 Hz to 16 kHz. Refer to Response Limits in Fig. 8-10 (B) above.

8-18 SIGNAL-TO-NOISE RATIO –OVERALL–

1. Output and Line controls should be at the specified positions.
2. Remove the AF oscillator from the LINE IN jacks.
3. Place the deck in the Record mode with “no signal” applied.
4. Note the point on the index counter where recording begins.
5. Rewind the recorded tape to the beginning point and play it back.
6. The noise level as indicated on the VTVM should be readings listed below.
-54 dB (1.54mV) or more **HIGH (7-1/2 ips)**
-51 dB (2.18mV) or more **LOW (3-3/4 ips)**

NOTE: This -54 dB/-51 dB corresponds to the Signal-to-Noise ratio of 49 dB/46 dB (minimum); the difference between residual noise of -54 dB/-51 dB and specified output level -5 dB.

NOTE: Since this measurement method and the measurement methods used to obtain the catalog and owner’s manual S/N spec. are different, the values here and in the catalog and Owner’s manual will be different.

8-19 MONOPHONIC RECORDING CHECK

SPEED Selector SW . . . HIGH (7-1/2 ips)

1. Place the RECORD MODE SW L (or R, not both) to ON and R (or L) to the OFF position.
2. Apply signals swept from 40 Hz to 20 kHz at -22 dB (61.5 mV) to LINE IN jacks and Record.
3. Check that output is within limits given in Fig. 8-10 (A), (B).
4. If adjustment is necessary, adjust DUMMY coil L373 for best response.
5. Repeat the LOW Speed check for best response. Use signals swept from 40 Hz to 16 kHz at -32 dB (19.4 mV). Check only. No adjustment is provided.

8-20 OPTIMUM ERASURE

SPEED Selector SW . . . HIGH (7-1/2 ips)

BIAS SW 2

EQ SW 2

1. Thread the YTT-8023 Test Tape on the deck.
2. Apply a 1 kHz signal at 10 dB above the operating level of -12 dB (194 mV) to the LINE IN jack.
3. Make a 30 seconds recording of the above signal while reading and noting the level of output, then rewind to beginning of this recording.
4. Disconnect the 1 kHz signal source (AF oscillator) from the LINE IN jack.
5. Connect a VTVM to the OUTPUT jack, through a 1 kHz Narrow Band Pass Filter.
6. Put deck in the Record mode and "record" (erase) over this previous recording, then rewind to beginning again.
7. Put deck in Play mode and monitor the output on the VTVM.
8. Difference in output level, between the 1 kHz signal and the "no signal" section level should be more than 70 dB.

NOTE: Filter loss should be considered.

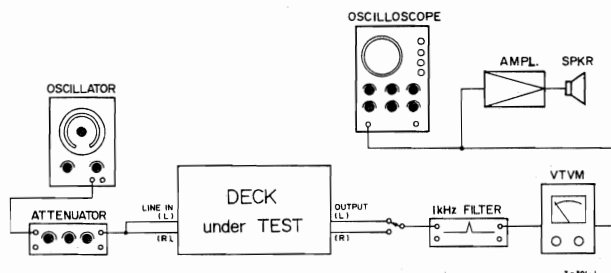

Fig. 8-11 Test Connections for Erase measurement

8-21 CROSSTALK REJECTION (TRACK-TO-TRACK)

9. Thread a blank or completely bulk erased YTT-8023 test tape on the deck.
10. Apply a 400 Hz (or 1kHz) signal at -12 dB (194 mV) to the left and right channels.
11. Make a 30 second recording of the above signal and while recording measure the off-the-tape output level (MONITOR SW at TAPE OUT).
12. Stop the tape and interchange the right and left reels and rethread the tape on the deck.
13. Playback the tape and measure the OUTPUT from the left and right channels (tracks 2 and 4). Compare these levels to the levels measured in step 3.
14. The difference between the two measurements should be 40 dB or more for the 125 Hz signal and 50 dB or more if the 1 kHz signal was recorded.

8-22 CHANNEL SEPARATION

SPEED Selector SW . . . HIGH (7-1/2 ips)

BIAS SW 1

EQ SW 1

1. Be sure tape YTT-8013 is completely bulk erased prior to doing these checks.
2. Apply a 1 kHz signal at -12 dB (194 mV) to L chan.
3. Place deck in Record mode.
4. While recording measure the OUTPUT on R chan with VTVM connected through a 1 kHz Band Pass Filter.
5. Reading should be 50 dB, or more.

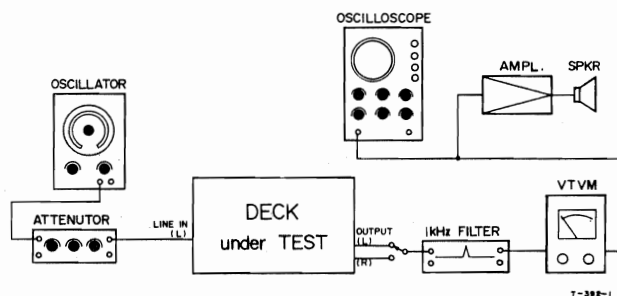

Fig. 8-12 Test Connections for Channel separation check

8-23 DISTORTION CHECK

6. Thread the YTT-8013 test tape on the deck.
7. Apply a 1 kHz signal to the LINE IN jacks at 0 VU.
8. With the Line and Output Level Controls set to the specified position, place the deck in the record mode for approx 10 seconds.
9. Rewind and play this recorded section of the tape.
10. The distortion factor read on the distortion analyzer should be 0.8% or less.

9. SERVICING AND MAINTENANCE

9-1 CLEANING:

TEAC TZ-261A for Head cleaning and TZ-261B for Rubber cleaning should be used. Use for following places.

TZ-261B	TZ-261A
Pinch roller rubber Capstan belt Counter belt	Motor pulley Heads, Brake drums Capstan shaft Tape run guides

9-2 LUBRICATION:

Under normal operating conditions, lubrication is required only once each year. Before lubricating, clean the drive belt and drive pulley... etc. Operate the deck for 30 minutes to 1 hour immediately prior to oiling. After oiling, keep the deck in the upright position for 3 to 4 hours to allow thorough absorption of the oil.

Approximately once each year or after 2000 hours of use, apply TEAC TZ-255 or equiv. Lubricating Oil to the following places only;

- Pinch roller shaft 1 drop
 - Capstan shaft 2 drops
- (Remove the dust cap for access to the oil pit)

NOTE: Excessive oiling will scatter oil inside the deck. This oil will cause drive belt slippage and other difficulties. Check for slippage and clean all parts inside the deck before operating after lubrication. Check for oil emission after operation and before returning deck to the customer.

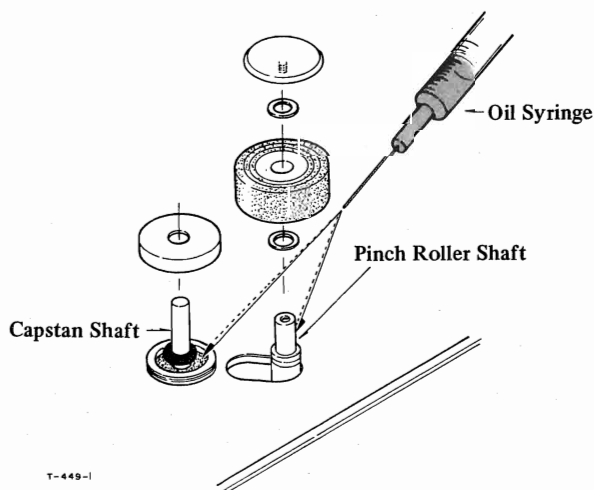

Fig. 9-1 Capstan Shaft and Pinch Roller Shaft Oiling Points

9-3 TEAC MAINTENANCE FLUIDS



Fig. 9-2 TZ-255 Oil Kit



Fig. 9-3 TZ-261 Tape Recorder Kit

9-4 DEMAGNETIZATION OF HEADS

If the record or Playback heads become magnetized, noise will increase and tonal fidelity will deteriorate. For this reason it is advisable to use non-magnetic tools when working near the heads. If the heads have had any contact with current or magnetized metal parts, demagnetize them with a TEAC E-3 eraser or Equivalent.

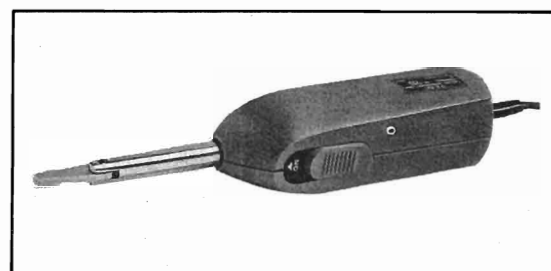

Fig. 9-4 TEAC E-3

10. SIMPLIFIED SCHEMATIC AND LEVEL DIAGRAMS

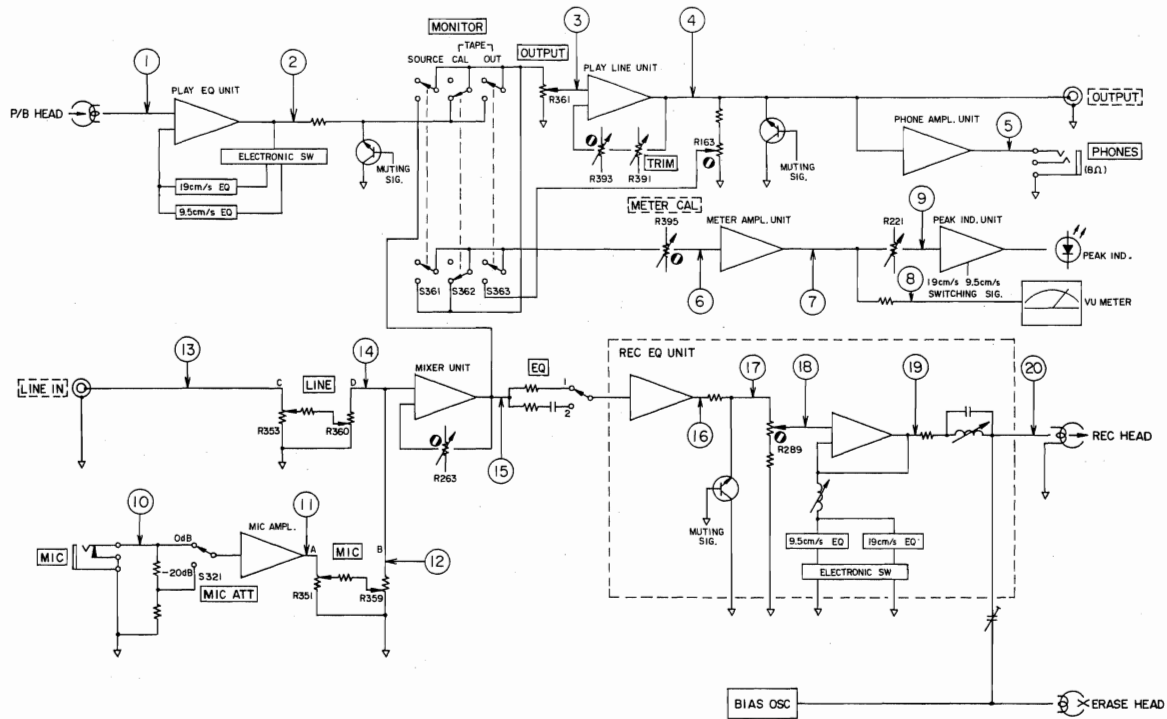
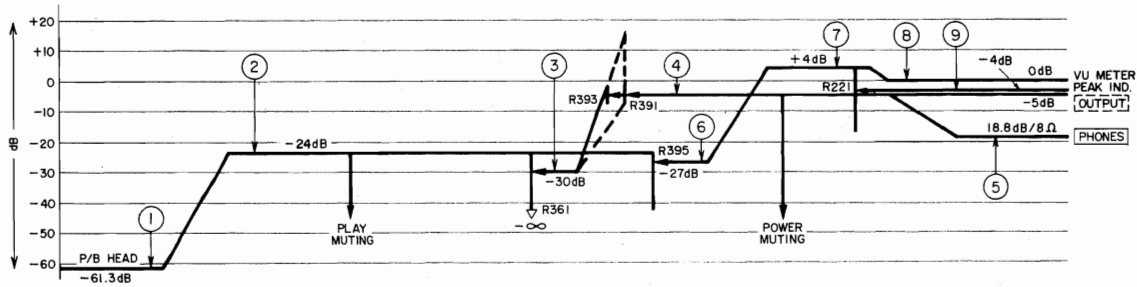
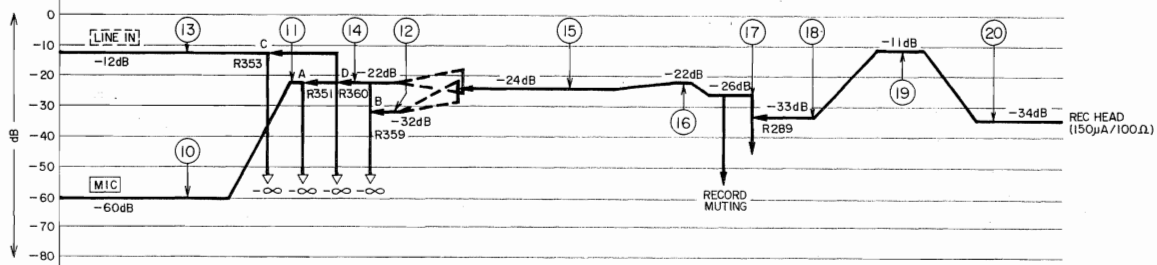

Fig. 10-1 Simplified Schematic Diagram

PLAYBACK



RECORD



NOTE: — Playback and Record Controls are Positioned at specified level.
 — Each level given in the diagram shows values when 400 Hz specified level is applied.
 — 0 dB = 0.775 V
 — Ref. Nos. shown in the diagram relate only to the left channel.

Fig. 10-2 Level Diagrams

11. THEORY OF OPERATION

— TABLE OF CONTENTS —

TAPE TRANSPORT CIRCUIT DESCRIPTION	28	AMPLIFIER CIRCUIT DESCRIPTION	44
1. CONTROL UNIT	28	1. PLAY EQ UNIT	45
1-1 FWD Play and REV Play Operation	30	1-1 EQ Switch	45
1-2 Fast Mode (F.FWD and REV)	32	1-2 Muting Unit	45
1-3 Mode Change from Fast Wind to Play	33	2. PLAY LINE UNIT	45
1-4 Record Mode	34	2-1 Standard Operational Amplifier	46
1-5 Record Pause Mode	34	2-2 Ideal Response	46
1-6 Auto Spacer Mode	36	2-3 Inverting Amplifier	46
1-7 Sensing Reverse	38	2-4 Non-Inverting Amplifier	46
1-8 Counter Repeat	38	2-5 Play Line Unit — Front Stage —	46
1-9 Stop Operation	39	2-6 Play Line Unit — Back Stage —	47
2. MOTION SENSING	40	3. PHONE AMPL. UNIT	47
2-1 Motion Sensing Signal Generating Circuit	40	4. METER AMPL. UNIT	47
2-2 Motion Sensing Control Section	40	5. PEAK IND. UNIT	47
3. REEL MOTOR DRIVE SECTION	42	6. MIC AMPL. UNIT	47
4. POWER SUPPLY CIRCUIT	43	7. MIXING UNIT	47
5. SPEED CHANGE AND REEL SIZE CHANGE CIRCUIT	43	8. RECORD AMPLIFIER	48
		8-1 Record Amplifier — Front Stage —	48
		8-2 Record EQ Unit	48
		9. MUTING UNIT (POWER)	48
		10. BIAS OSC UNIT	49
		11. BASIC TIMING CHART	50

— AN AFTERWORD —

TAPE TRANSPORT CIRCUIT DESCRIPTION

In the tape transport section of the Model A-6600, a DC Servo Controlled Motor is employed for capstan drive and AC Eddy Current Induction Motors are used for reel drive. The tape transport control section is made up of discrete circuits built with transistors and diodes. Reel motor control, however, is operated by switching action of relay circuits because the reel motors are driven by AC.

1 CONTROL UNIT

Each basic circuit function is explained in this section. Then, in the following sections, overall operation descriptions are given. For the following explanations of the Control Unit, the initial state for all circuits will be stop condition, unless otherwise noted.

(1) INVERTER

This circuit has the function to invert any signal into the opposite condition.

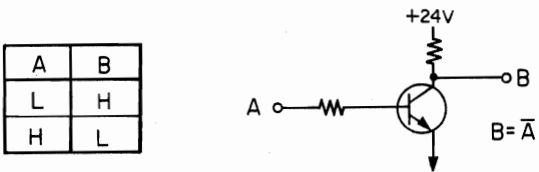

Fig. 1

(2) NAND GATE

This circuit has two or more inputs. The output will become L only when all inputs go H.

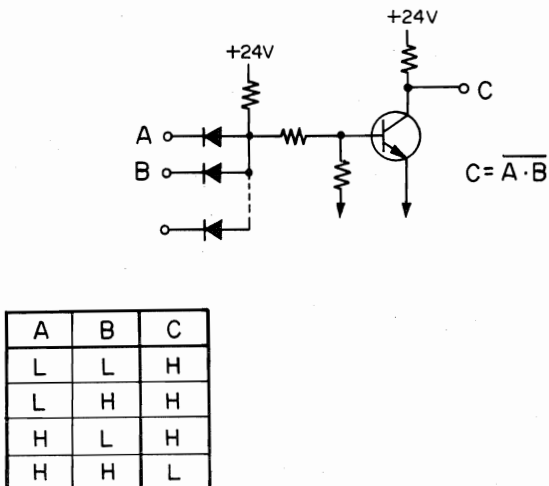
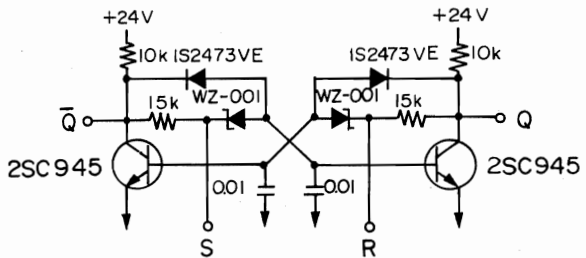

Fig. 2

(3) SET-RESET FLIP FLOP

Job of this circuit is to maintain a stable active output once an active input signal is applied, and memorize that state even though this input signal is removed. In the schematic, this circuit is indicated as U1-U5.



S	R	Q	Q̄
L	L	H	H
L	H	H	L
H	L	L	H
H	H	Qn-1	Qn-1

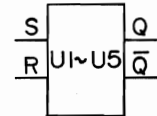

Fig. 3

(4) MULTIVIBRATOR

This circuit generates alternate H and L signals with approx. 0.7 sec interval and is used to flash RECORD LED and PAUSE LED.

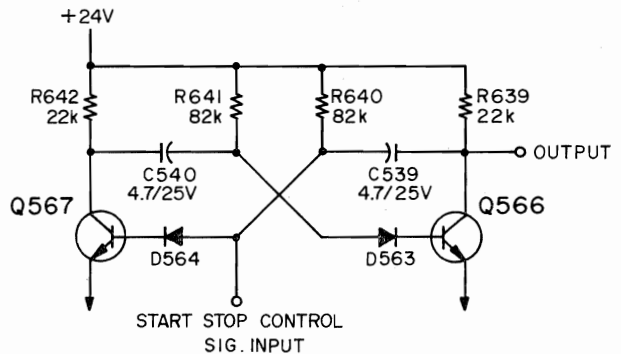

Fig. 4

(5) MONOSTABLE (ONE-SHOT) MULTIVIBRATOR

Two kinds of circuits are employed. MONO-MULTI (A) will be triggered when tape motion direction is changed from Forward to Reverse, or from Reverse to Forward, and produces approx. 0.5 sec width signal. MONO-MULTI (B) is provided for Auto Spacing function. Its final stage works as

an inverter. When MONO-MULTI (B) is triggered, OUTPUT will send out L level signal. This signal width is variable within the range of approx. 2 to 7 sec using AUTO SPACER control.

MONO-MULTI (A)

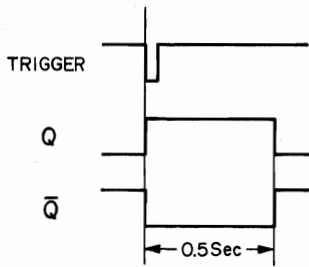
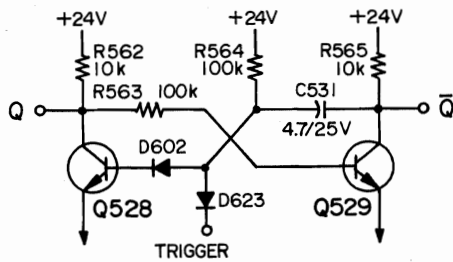

Fig. 5

MONO-MULTI (B)

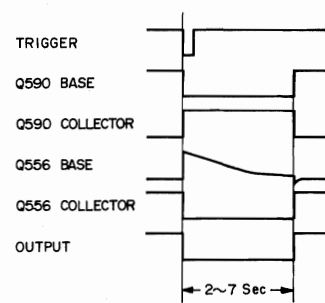
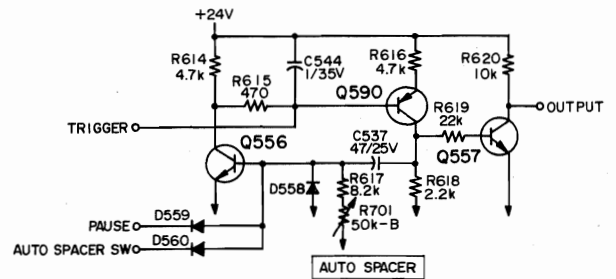

Fig. 6

1-1 FWD PLAY AND REV PLAY OPERATION

Fig. 7 shows partial circuit related to Forward Play and Reverse Play operations. When Forward button is depressed, Flip Flop U1 will be set. Then, since \bar{Q} output of U1 changes H to L, Q532 is turned OFF and the collector of Q532 will be changed L to H. At this time, since Q537 is OFF and its collector is H, the emitter of Q538 will go to H and Q584 will go to ON state to energize Forward Capstan Solenoid which works to press right hand side pinch roller against right hand side capstan. Also, at the same time that Q532 is turned OFF, Q534 is turned OFF and its collector goes from L to H. Since, at this time, Q544 is OFF and its collector is at H, the emitter of Q545 will go to H and Q586 will go ON. As a result of this, BRAKE Solenoid is driven to release brake function. Also, together with Q586, Q535 will go to ON state so that OPERATION RELAY (K735) is activated to apply voltages to reel motors. By the operation of each of these things mentioned above, deck will be set in Forward Play Mode. SOL. FLASHING signals which control voltages applied to solenoids are simultaneously sent out together with drive signals for each solenoid, and Forward (Reverse) Capstan Solenoid and Brake Solenoid are energized by short term drive circuit operation so that they are driven by 48V for approx. 300 mSec after SOL. FLASHING signals are applied, then are held by 24V. This operation is explained in paragraph 4-4. Reverse Play works with almost all the same process as Forward Play. When going to Reverse Play mode, outputs different from Forward Play are the following three points:

1. Reverse Capstan Solenoid is substituted for Forward Capstan Solenoid.

2. Reverse Relay action is added by ON state of Q541. The take up torque and back tension functions of the reel motors are reversed by the reverse relay from those performed during Forward Play.
3. Head Relay operation is added by means of ON state of Q558.

The Head Relay changes the Forward Playback Head for playback of forward tracks (1-3) to the Reverse Playback Head for playback of the reverse tracks (2-4).

When Play operation is changed from Forward to Reverse, or from Reverse to Forward, differentiation circuit will work to trigger Monostable Multivibrator consisting of Q528 and Q529.

Output from Monostable Multivibrator causes deck to go momentarily to STOP mode, then to go to Reverse Play mode from Forward Play mode, and vice versa. If Forward and Reverse buttons are depressed at the same time, U1 and U2 will both be in reset states, and their outputs \bar{Q} will both be at H. For the above reason, Q534 will go to ON state, which thus Q586 and Q535 both to be turned OFF in order to release BRAKE Solenoid and OPERATION RELAY. Also, since Q532 and Q533 are ON, Q584 and Q585 will go into OFF states to release both Capstan Solenoids. Accordingly deck will be put in Stop state. When the Forward Play and Reverse Play buttons are released almost at the same time, whether the deck goes into Forward Play or Reverse Play depends on which button is released last. Fig. 8 shows Timing Chart for Forward Play and Reverse Play modes.

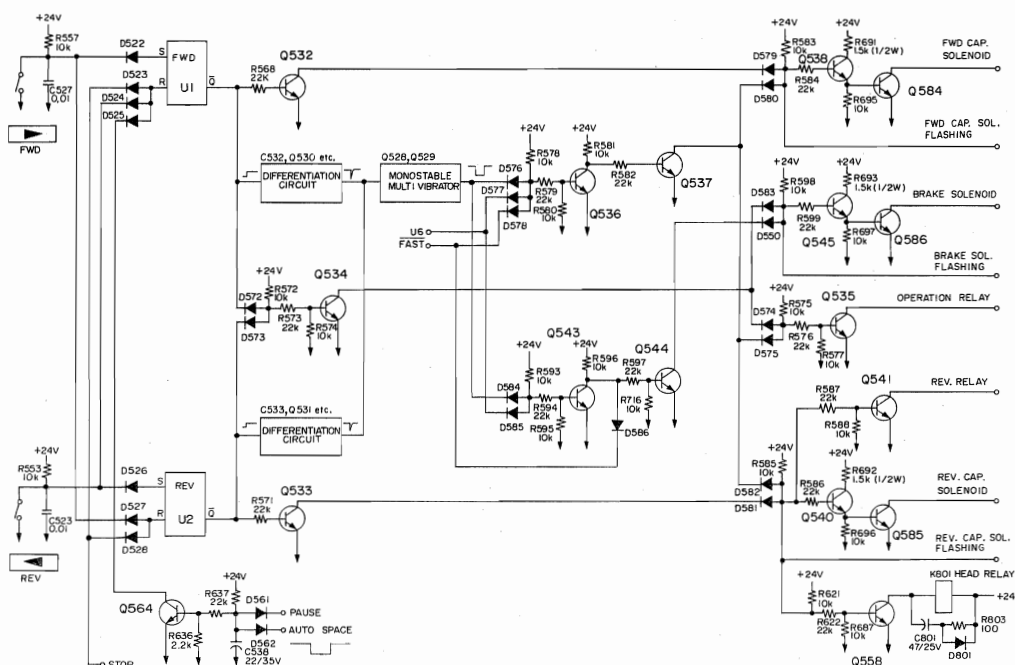

Fig. 7

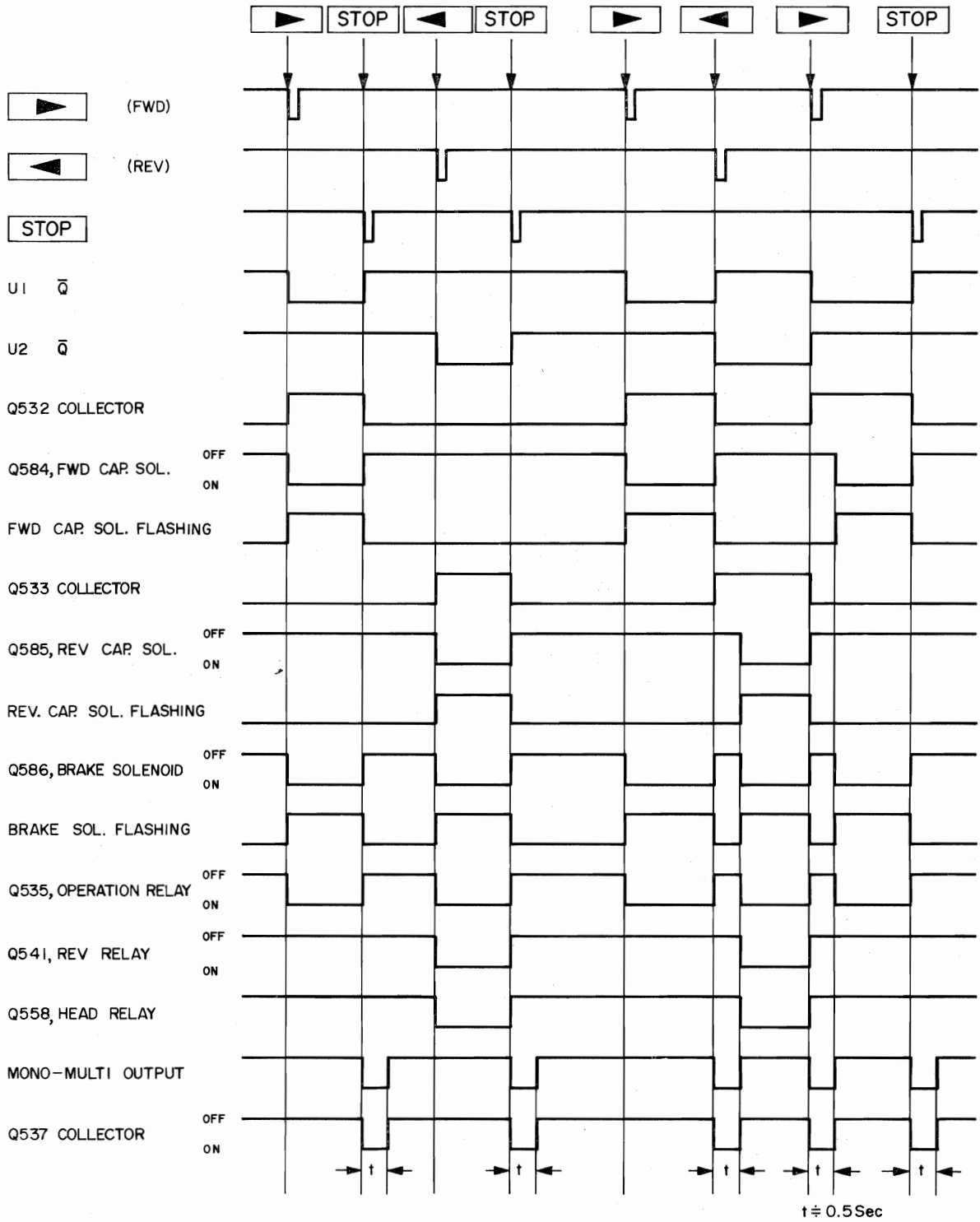

Fig. 8

1-2 FAST MODE (F. FWD AND REW)

Fig. 9 is partial schematic related to Fast Forward and Rewind operation. Timing Chart for this operation is indicated in Fig. 10. To set deck in Fast mode, there are the following two ways.

1. Depressing Forward (or Reverse) and FAST buttons simultaneously.
2. Depressing FAST button during Forward Play mode or Reverse Play mode.

When in Forward Play mode, $U1\bar{Q}$ will go L and when in Reverse Play mode, $U2\bar{Q}$ will go L. In either case, Q534 and Q539 will go to OFF States, and their collectors will go to H. When Q539 is OFF, if the FAST button is depressed Q591 will go ON and its collector will go L, which sets the Fast Flip Flop U3. When \bar{Q} of U3 goes L if turns OFF Q542 and then its collector will go H. At that time, if FWD (U1) has been put in set state, Q550 will go to ON state and F.FWD Relay K733 will be energized to set deck in Fast Forward mode. In the same way as explained above, if the REV (U2) has been set, Q551 will go to ON state to energize REWIND Relay (K732), which sets deck in Rewind mode. F.FWD and REWIND Relays are provided for converting reel motor voltages. This operation is depicted in paragraph 3. When $U3\bar{Q}$ is at L, both input and output of U6 will go L, and Q552 will be turned OFF. Then emitter of Q553 goes H, which makes Q587 go to ON state to activate Lifter Solenoid. Lifter Solenoid is provided to separate tape from head when in Fast Wind mode. Brake Solenoid action

when going into Fast Wind mode is as follows. If the deck was in Forward Play or Reverse Play just prior to the time that the FAST button was depressed, the U6 output and MONO MULTI output (collector of Q529) would both have been H and Q543 would be in ON state and Q554 would be in OFF state. Since Q544 together with Q534 were OFF state, emitter of Q545 has been at H and Q586 has then been ON state, consequently Brake Solenoid has already been in operation. If the deck was in STOP mode just before the time that the deck is put in Fast Wind mode, Q586, because of ON state of Q534, would have been turned OFF, so that Brake Solenoid would have been de-energized. When FAST button is depressed simultaneously together with Forward or Reverse button, Q534 goes to OFF state and \bar{Q} of U3 to L, accordingly Q544 becomes OFF state and Brake Solenoid will be operated. During Fast Winding mode, the deck can be changed to Fast Forward or Rewind mode by depressing only the Forward or Reverse button, respectively. Also, of Forward and Reverse buttons are simultaneously depressed, brake will function to set deck in STOP mode as explained in paragraph 1-1. When buttons are released, Fast Wind mode direction will be in accordance with the button which is released last. When Cue switch button is depressed while in Fast Wind mode, Lifter Solenoid will be released to put deck in Cue condition. Regardless of tape travel direction, when TRACK 1-3 or 2-4 CUE button is depressed, tracks number 1-3 or 2-4 can be put in Cue condition, respectively.

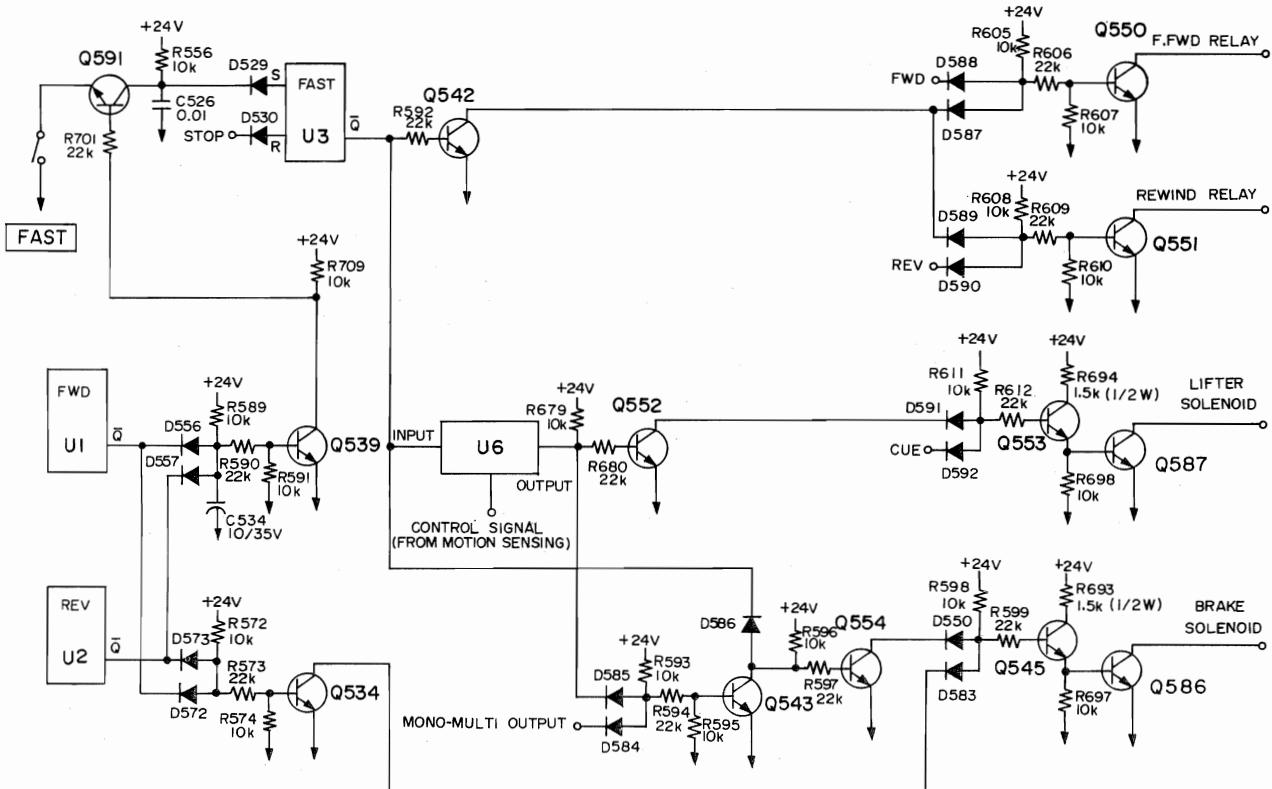

Fig. 9

1-3 MODE CHANGE FROM FAST WIND TO PLAY

Mode change directly from Fast Forward or Rewind mode to Forward Play or Reverse Play mode cannot be done. When doing so, STOP button should always be depressed to momentarily reset Fast Flip Flop U3. When depressing STOP button then Forward or Reverse button during Fast Forward or Rewind mode, initially, Fast Flip Flop U3 will be in reset state which makes $U3-\bar{Q}$ become H. When U6 input changes from L to H, its output will go from L to H, after a slight delay time. (This delay time is determined by Motion Sensing Circuit operation which works to set deck in Play mode after tape motion is completely halted. Refer to paragraphs 2-1 and 2-2 for the explanation on this.) Since U6 output is still kept L at the instant $U3-\bar{Q}$ goes into

H, collector of Q543 will go into H, which lets Q544 be turned ON. The result is that Brake Solenoid is de-energized to activate brake function. After tape movement is completely stopped, U6 output will go from L to H. Therefore Q543 will go ON, thereby Q544 goes to OFF. Since, up to this time, Q534 has gone to OFF state due to $U1-\bar{Q}$ or $U2-\bar{Q}$ output (because Forward or Reverse button is already depressed), Q586, when Q544 is turned OFF, will go to ON state to drive Brake Solenoids which release Brakes. On the other hand, when U6 output goes to H, Q552 will go to ON state which causes Q587 to go OFF. The result is that Lifter Solenoid will also be released. As a result of the above, deck is set in Forward or Reverse Play mode. For timing of these operation, refer to Fig. 10.

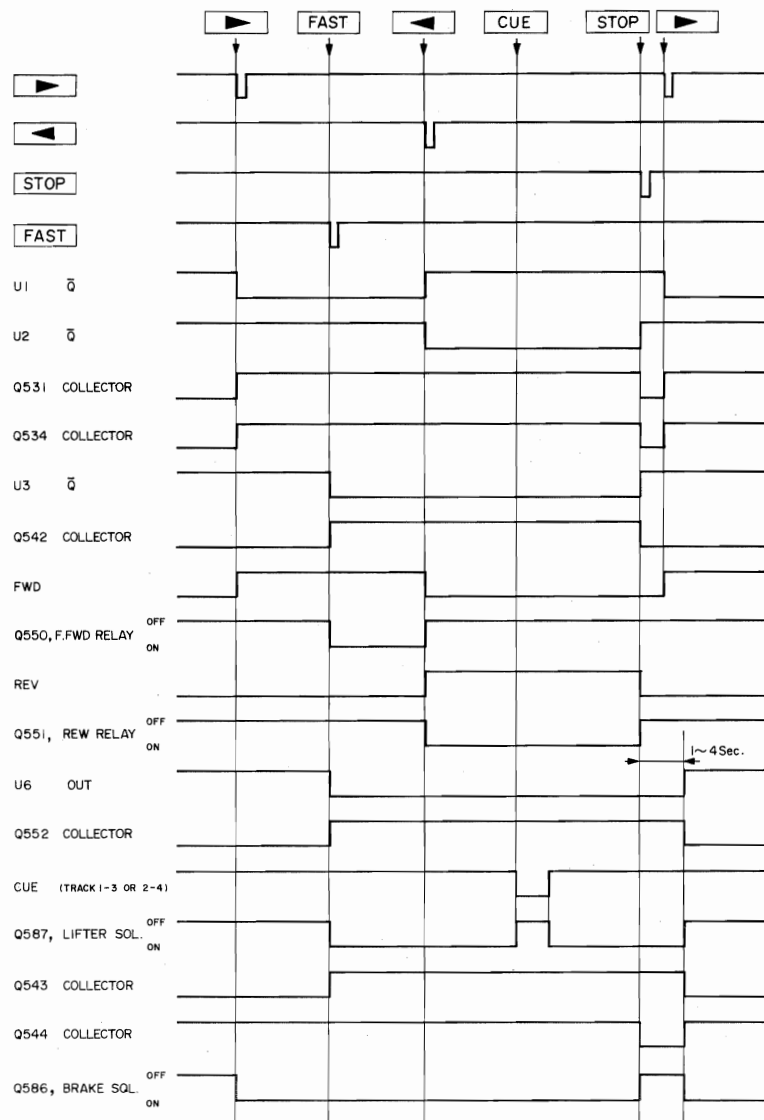

Fig. 10

1-4 RECORD MODE

Fig. 11 is partial circuit related to RECORD mode. Fig. 12 is Timing Chart for the circuit. When both RECORD MODE buttons, L and R, are switched OFF, REC. Flip Flop U4 and Multivibrator (consisting of Q566 and Q567) are reset. When REC MODE switch, L and/or R-ch, are depressed to ON, reset state of U4 will be released, and simultaneously Multivibrator will begin oscillation. This oscillation output allows Q582 to go ON-OFF alternately for blinking of RECORD LED (colored with RED). Now, assume that RECORD and Forward buttons are pressed down at the same time. By depressing Forward button, deck will be put in Forward Play operation as mentioned previously. Simultaneously, U4 will go into set state, which inverts U4-Q output from H to L. For this reason, Q549 will be switched OFF, and its collector, in turn, will go H, and this H makes Q561 go to ON state, and RECORD LED,

as a result, will be lighted. Since Q output of mono-multi-vibrator (Q528, Q529) is normally L, Q581 will be OFF and U6 output will remain H. Therefore, when Q549 is turned OFF, Q562 will go ON and Q563 will go OFF. With Q563 OFF its collector will go H, which allows Q562 to transmit REC SIGNAL, and the Bias Oscillator begins Oscillation. In addition to the above, Q565 and K511 will be operated. K511 is provided for connecting Record Head to Record EQ Amplifier output circuit. Furthermore, since the Q563 collector leg and the FWD leg (coming from collector of Q532) of the NAND gate are both H (AUTO SPACE signal leg is normally H also), REC MUTE signal will go H. When REC MUTE signal is H, Muting function for Record EQ Amplifier is released. Record mode will be released when either STOP, Reverse or FAST button is depressed. Also, when PAUSE button is depressed, deck will be set in Record Pause mode.

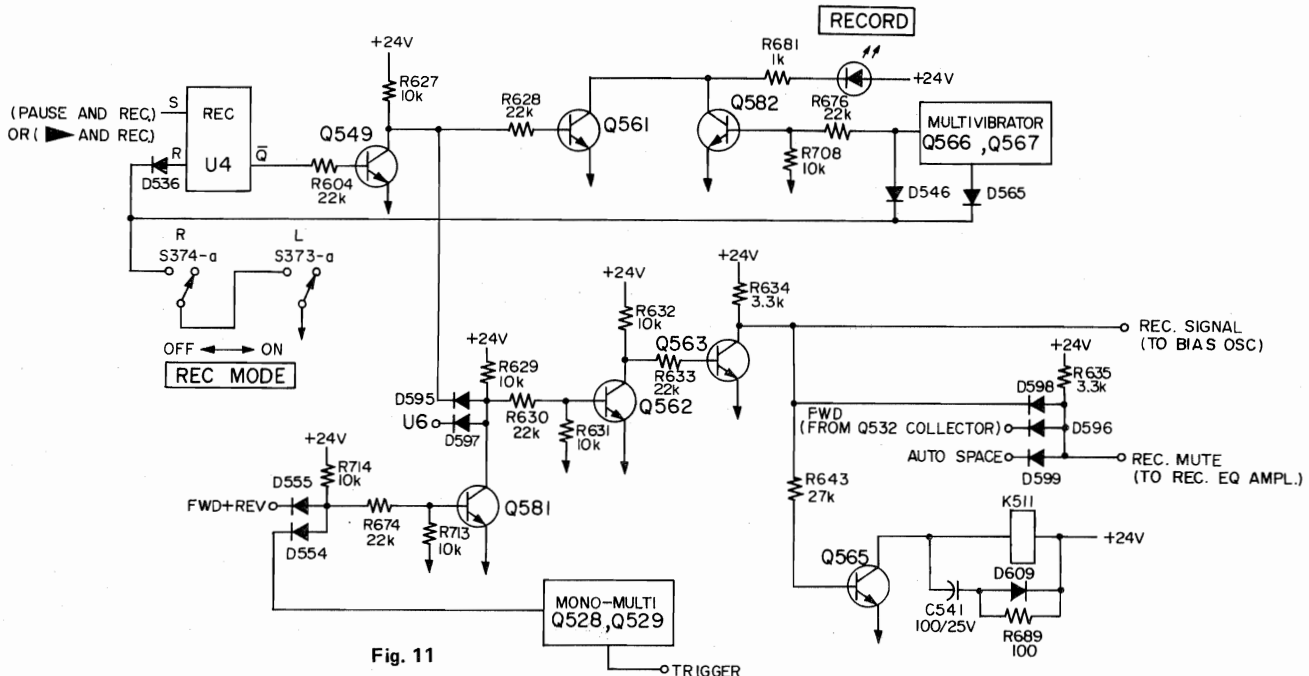

Fig. 11

1-5 RECORD PAUSE MODE

This deck will go to Record Pause mode when RECORD and PAUSE buttons are pressed at the same time during STOP or Forward Play mode, or when the deck is already in Record mode and then PAUSE button is pressed. Referring to Fig. 11, when RECORD and PAUSE buttons are pressed at the same time while RECORD MODE switch(es) is positioned at ON, REC. Flip Flop U4 is put in set state, which allows Q549 to be in OFF state. Q561 will be turned ON to steadily light RECORD LED. In addition, as with Record mode, REC SIGNAL will go into H so that Bias Oscillator will be activated. Furthermore Q565 and K511 will both be in ON state for Record Head to be connected with Record EQ Amplifier output. Since, however, FWD signal is at L, REC. MUTE signal will be L, so Record EQ

Amplifier does not operate. On the other hand, referring to Fig. 13, when PAUSE Flip Flop U5 is put in set state, and thus makes Q560 go OFF, Q571 will be switched ON so that PAUSE LED (green) will be lighted steadily. During Record Pause mode, since OPERATION signal is L which makes Q569 go OFF, and Q568 is set in OFF state due to L output of U4-Q, Q570 will go to ON state. The result is that PLAY MUTE signal will be L. For this reason, Muting function is provided to Play EQ Amplifier. When Forward button is depressed during Record Pause mode, PAUSE Flip Flop will be put in reset state, thereby causing extinguishing of PAUSE LED. And then, each Muting function will be released and deck will be set in RECORD mode as REC Flip Flop still remains in set state. Fig. 14 indicates Timing Chart associated with Record Pause function.

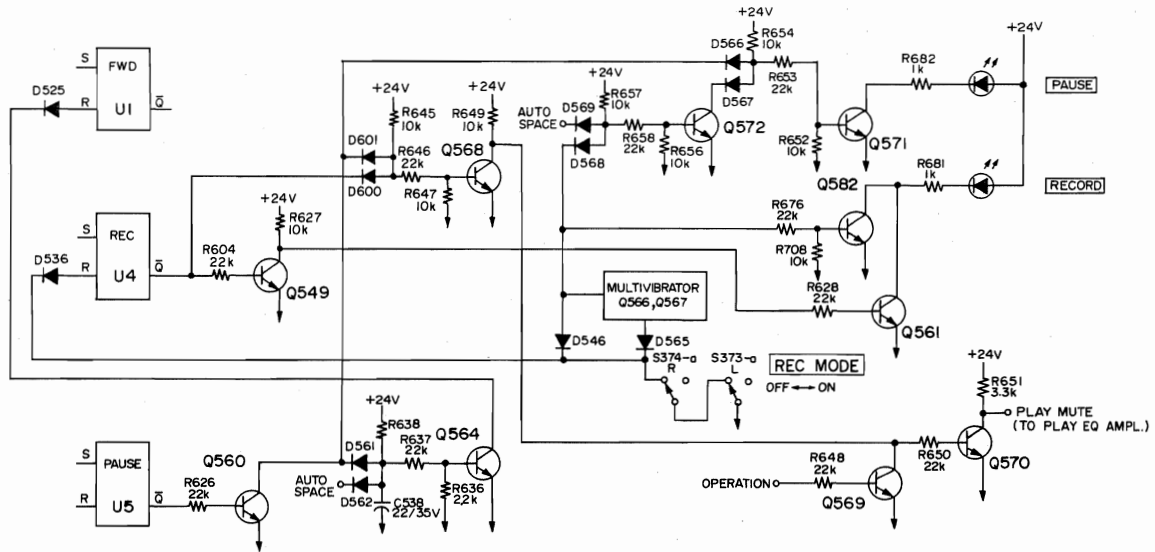

Fig. 12

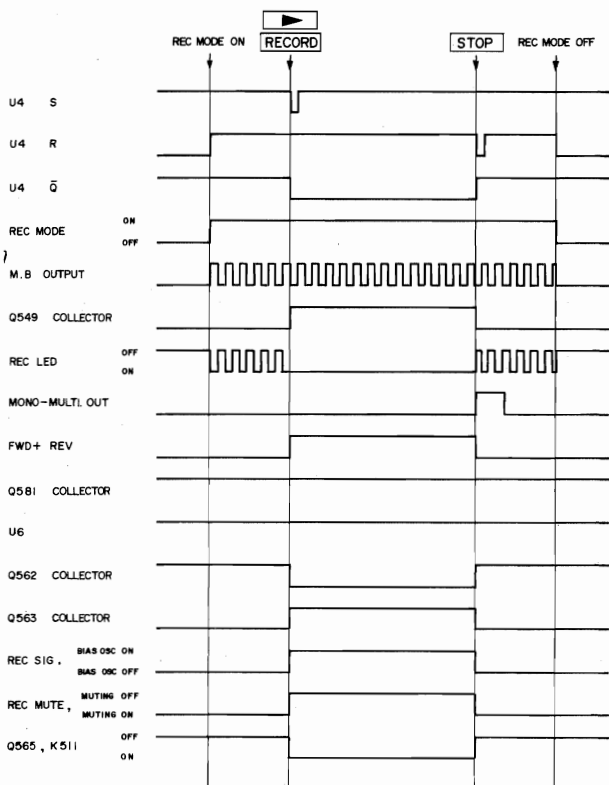

Fig. 13

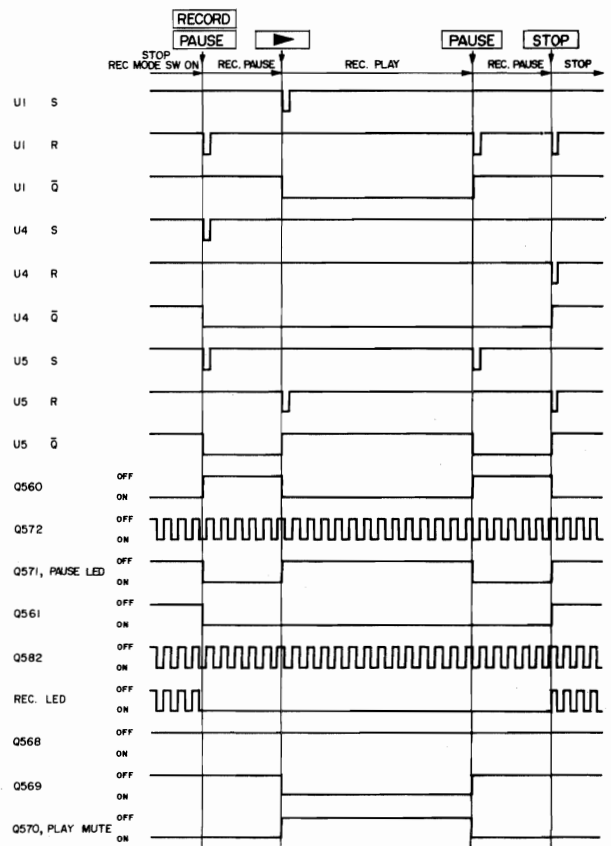

Fig. 14

1-6 AUTO SPACER MODE

AUTO SPACER function is provided for making non-recorded signal portions (spaces), for example, between some musical selections to be recorded on the tape. Now, let us assume that AUTO SPACER Switch (S701) is pulled out (ON position) with deck in RECORD mode. Refer to Fig. 15. Up to this time, $U4\bar{Q}$ has been at L, so collector of Q549 has gone H; while $U1\bar{Q}$ has been at L, thus it results that collector of Q532 is in H state. Since, however, $U5\bar{Q}$ was H and Q560 collector was L, point A would go L. For this reason, Q554 has gone to OFF. Furthermore Q556, Q590 and Q557 have been at OFF state. Since collector of Q557 was H, also REC and FWD signals were H together, REC MUTE signal has been H, accordingly Muting function of Record EQ Amplifier has been released. Also since Q560 was switched ON, subsequently Q571 went into OFF state, PAUSE LED would be extinguished. When PAUSE button is depressed with these conditions, $U5\bar{Q}$ will go L, and Q560 will be switched OFF, then point A will become H. This H signal at point A passes through C536, and a

moment later makes Q554 go ON and the Mono-multi is triggered. When Mono-multivibrator is triggered, Q590 and Q556 will both go to ON state, and will make Q557 go to ON state which causes L level from Q557 to be sent to point B as AUTO SPACE signal. This signal returns to H after a period of time determined by AUTO SPACER control R701 (approx. 2 to 7 seconds). Since REC MUTE signal is L as long as point B is at L, Muting signal is applied to Record EQ Amplifier. In addition to above, for that duration, since Q573 is in OFF state, Q572 and Q571 will be turned ON-OFF by the Multivibrator (Q556 and Q567) output which creates flashing ON-OFF of PAUSE LED. When point B goes to H, the H on the collector of Q560 makes the output of the AND gate H, Q564 is turned ON and the FWD Flip Flop, U1, is reset. When U1 is reset, the tape movement is stopped and the deck goes to the Record Pause mode. In other words, during RECORD mode, after the PAUSE button is depressed until the time that U1 is reset, a no-signal recording is being made on the tape. Fig. 16 denotes Timing Chart for AUTO SPACER operation.

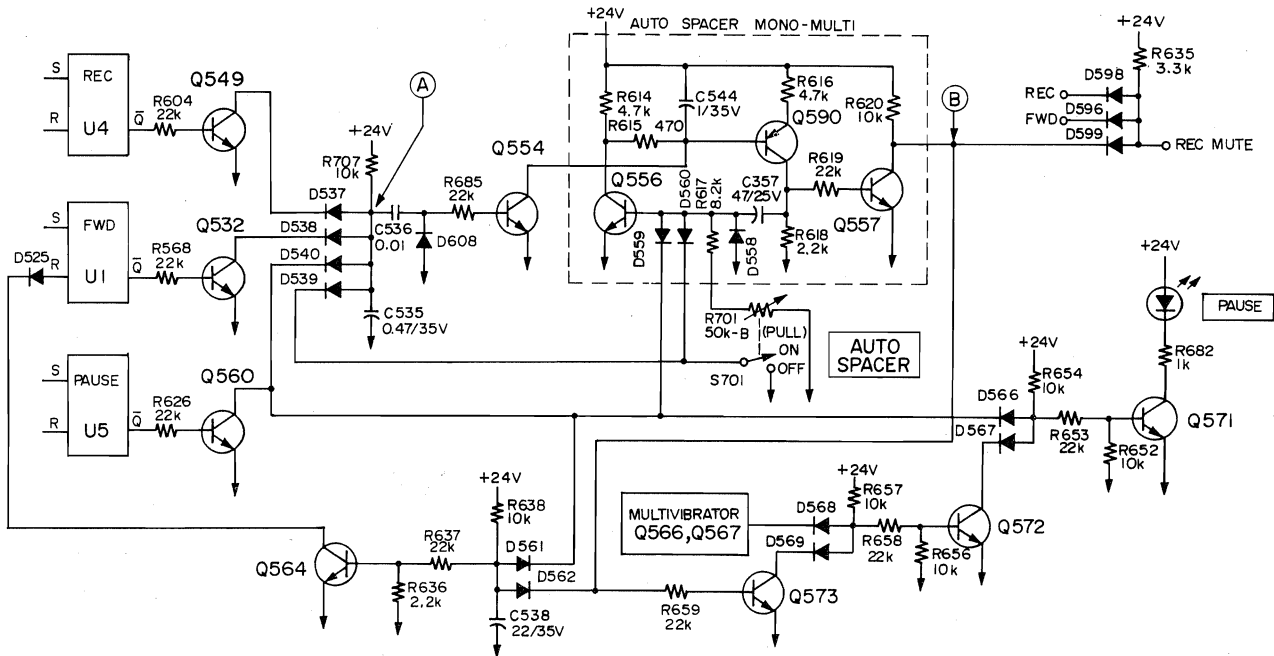

Fig. 15

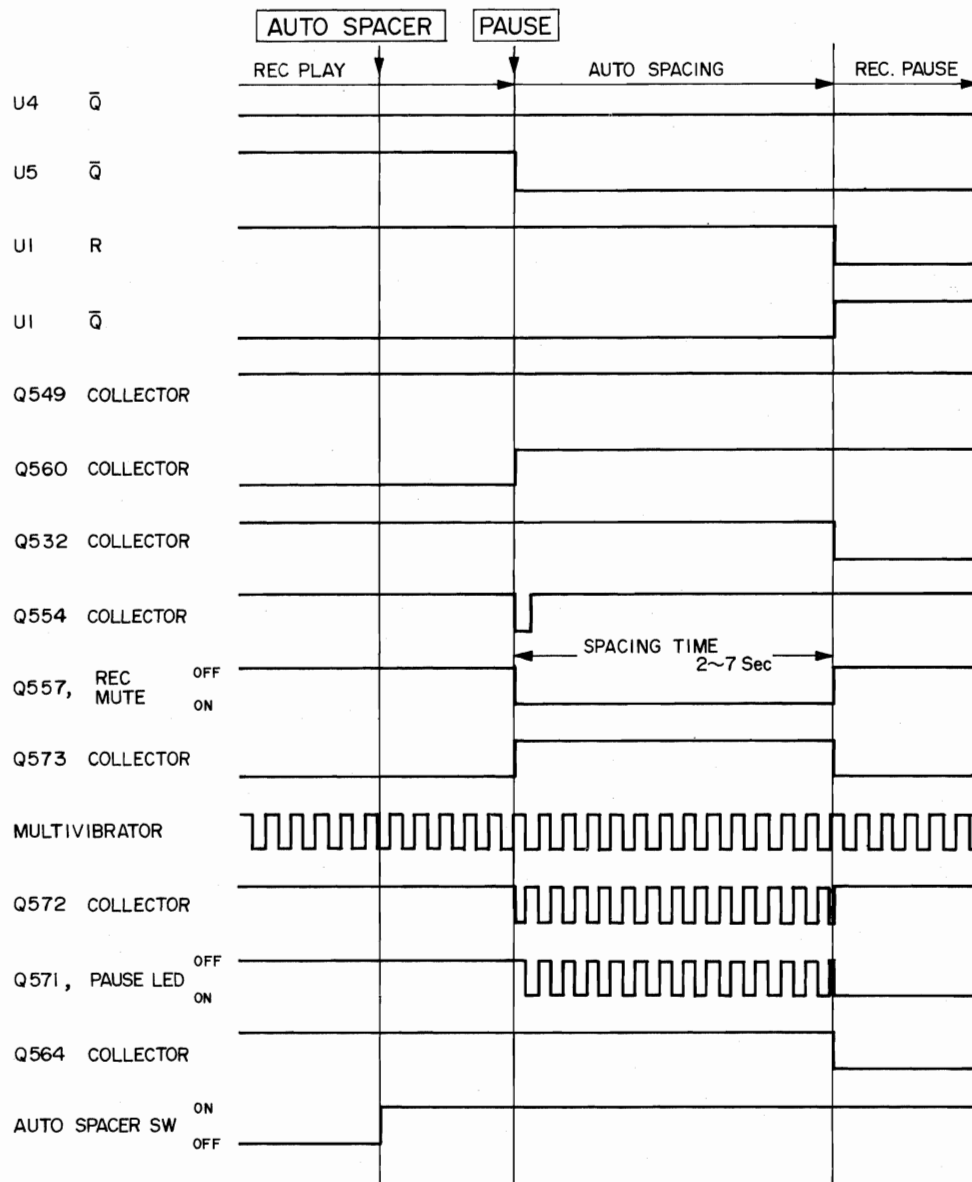

Fig. 16

1-7 SENSING REVERSE

Refer to Fig. 17 and 18. When Sensing Foil which was affixed beforehand on the tape is detected during Forward Playback operation, Q575 will go to OFF state. Since $\overline{\text{FAST}}$ signal and FWD + REV signal are H together, Q574 will go to ON state. This ON state of Q574 permits reset

state of FWD Flip Flop U1 and set state of REV Flip Flop U2, consequently deck will be put in Reverse Play mode. Since $\overline{\text{FAST}}$ signal is L during Fast Wind mode, Q574 will not go ON even though Sensing Foil is detected.

1-8 COUNTER REPEAT

REPEAT switch (S782) and switch (S783) that is closed during the time that counter is at "9000" to "9999" are installed on the counter of this deck.

During Reverse Play, if the REPEAT Switch is ON, when the counter changes from "0000" to "9999" and S783 closes, the electric charge on C530 will flow through R670 to the base of Q579 making Q579 go ON momentarily. Q576 will go OFF and its collector will go H. Since FWD + REV and $\overline{\text{FAST}}$ are H, Q527 will go ON, REV Flip Flop,

U2, will reset and at the same time FWD Flip Flop, U1, will be set.

As a result of this, deck mode is changed from Reverse Play to Forward Play. By means of the combination of this operation and Sensing Reverse operation, Repeat operation is conducted. Since during Fast Wind mode, $\overline{\text{FAST}}$ signal is L, Q527 will maintain OFF state. The circuit and Timing Chart regarding this section are shown in Fig 17 and 18.

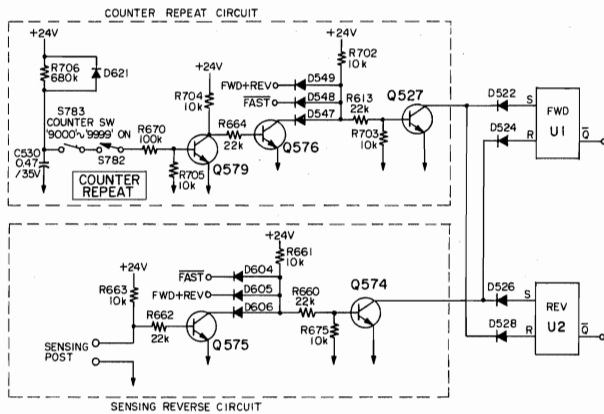

Fig. 17

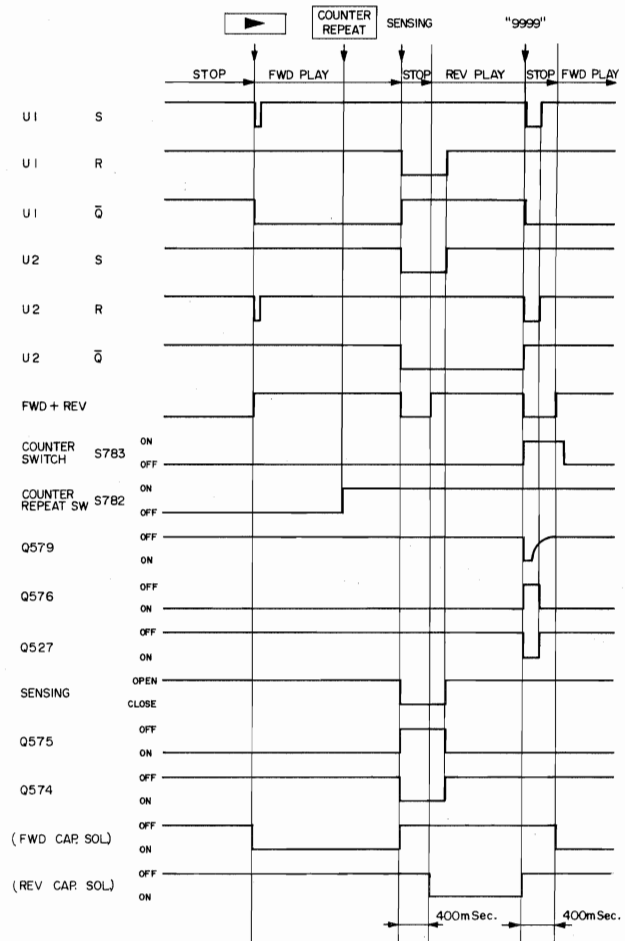

Fig. 18

1-9 STOP OPERATION

Fig. 19 is the circuit for STOP operation. STOP signal is transmitted by any of the following conditions: STOP button is depressed, or both left and right Tension Arms are positioned down, POWER switch is turned ON and OFF. STOP signal is applied to reset inputs of each Flip Flop and has priority over any operation signals. Since S784 and S785 are grounded when both left and right Tension Arms are lowered, Q583 will be switched OFF, then Q580 will be turned ON, the resulting STOP signal L is sent out from collector of Q580. At this time, MOTOR STOP signal goes to H, this controlling Capstan Motor Power Supply circuit to prevent the Motor from being supplied voltage. Power Reset Circuit is provided for transmitting STOP signal when POWER switch is turned ON and OFF. When +24V rises as main power is switched ON, C543 will

be quickly charged through D571, the resultant rise of Q577 emitter potential will be obtained.

C547, since it is charged via R665, will charge slowly compared to C543.

Until C543 is sufficiently charged, that is, during the time potential at Q577 base is lower than potential at its emitter, Q577 will be in ON state. Therefore, for this period, Q578 will also go to ON state, thus STOP signal will be sent out.

When POWER switch is shut off, +24V will drop relatively quickly. Electric charge of C547 is discharged via D570 at the same time as +24V falls off. Since, however, C543 is inhibited by D571, it does not discharge toward +24V side. Accordingly since potential at base of Q577 is lower than potential at its emitter, Q577 will be ON and also Q578 will be ON state, and STOP signal will be sent out.

Fig. 20 is Timing Chart for STOP operation.

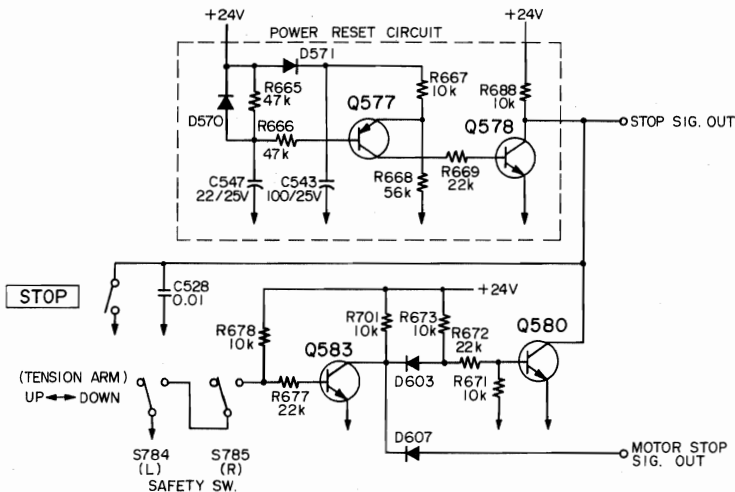

Fig. 19

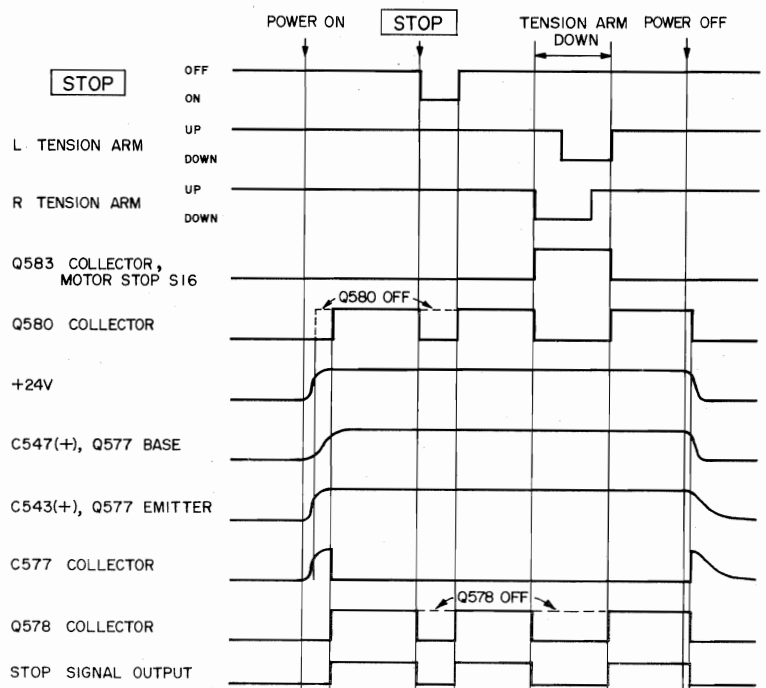

Fig. 20

2 MOTION SENSING

This deck is designed so that, during Fast Wind mode, STOP button is depressed then, immediately after which Forward or Reverse button is pressed down, the deck, after tape motion is completely halted, will conduct next operation, Forward Play or Reverse Play.

Motion Sensing circuit is designed for detecting whether this tape is completely stopped or not, and then controlling the next operation.

2-1 MOTION SENSING SIGNAL GENERATING CIRCUIT

Ring Magnet shown in Fig. 21 is installed on Guide Roller shaft on tape transport. Since Guide Roller does not rotate while deck is in STOP state, Ring Magnet mounted on its shaft will also be stopped. As a consequence, Magnetic Resistance Element will not generate a signal. Therefore Q751 does not operate, that is, does not amplify the signal, and Q752 is in OFF state. C757 and C754 are charged and Q753 is in ON state. During each Play, Fast Forward and Rewind mode, Ring Magnet is rotating and a signal is generated by Magnetic Resistance Element. This signal will be amplified by Q751.

Due to output from Q751, Q752 goes ON-OFF repeatedly. For this reason, electric charges on C757 and C754 are discharged; and because base potential of Q753 is L while Q752 goes repeatedly ON and OFF, Q753 will be switched OFF. As a result of this, output from Q753 collector will go into H while Guide Roller is turning (in other words tape is moving) and will go L while deck is stopped. See Fig. 23 for Timing Chart of this section.

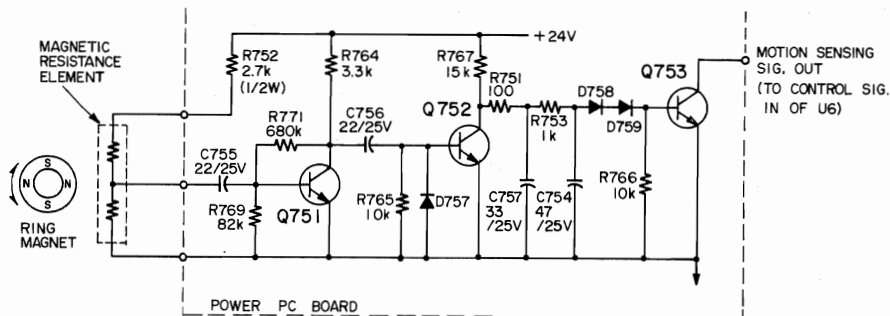

Fig. 21

2-2 MOTION SENSING CONTROL SECTION

See Fig. 22. At U6 input terminal, L is applied when in Fast Wind mode, and H when in the other modes. Now suppose that deck is changed from STOP or PLAY mode to Fast Wind mode, then since U6 input goes L, Q521 will go to OFF state. Current flowing through R542, C521, D615 and Q523 turns ON Q523 for a certain time.

Also, current flowing through R542, R543 and Q522 makes Q522 go ON. Emitter currents of Q522 and Q523

charge C522, and then raise base potential of Q524. When Base potential at Q524 increases past a certain value, Q524 will go to ON state then Q525 will go to OFF state, finally Q526 will be switched ON.

As a result of this, output terminal of U6 goes into L, thus sending out the signal which is necessary for Fast Wind mode.

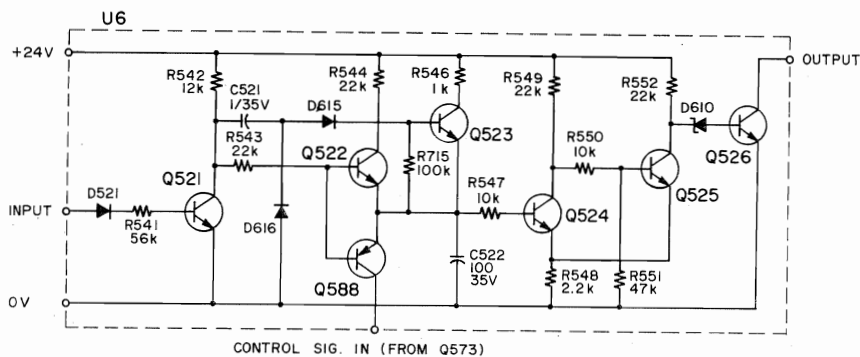

Fig. 22

When STOP button is depressed during Fast Wind mode, U6 input will be inverted to H, and Q521 will go to ON, Q522 OFF and Q588 ON. In addition to the above, when STOP button is depressed, deck will be put in STOP mode and Brake Solenoid will be de-energized to activate Brake function to Reel Motors. However, Reels continue to turn for a while due to the effect of inertia during which time tape is traveling.

Since, as previously described in paragraph 2-1, the Guide Roller is rotating as long as tape is running, Q753 is in OFF state, the result is that current does not flow even though Q588 connected to Q753 goes to ON. For this duration, charged voltage potential on C522, as the current does not

flow to Q588, will gradually flow to Q524, which therefore remains switched ON, and Q525 will be kept OFF and Q526 ON. Since when tape motion is stopped, Q753 goes ON, electric charge of C522 will be discharged via Q588 and Q753.

For the above reason, Q524 is switched OFF, Q525 ON and Q526 OFF in order.

When U6 output goes to H due to Q526 going OFF, deck can be changed to the next mode. In Fig. 22, Schmitt circuit comprised of Q524 and Q525 gives snap characteristic to switching of transistor. D610 is zener diode for level shifting and its purpose is to make Q526 action stable. Fig. 23 is Timing Chart related to Motion Sensing operation.

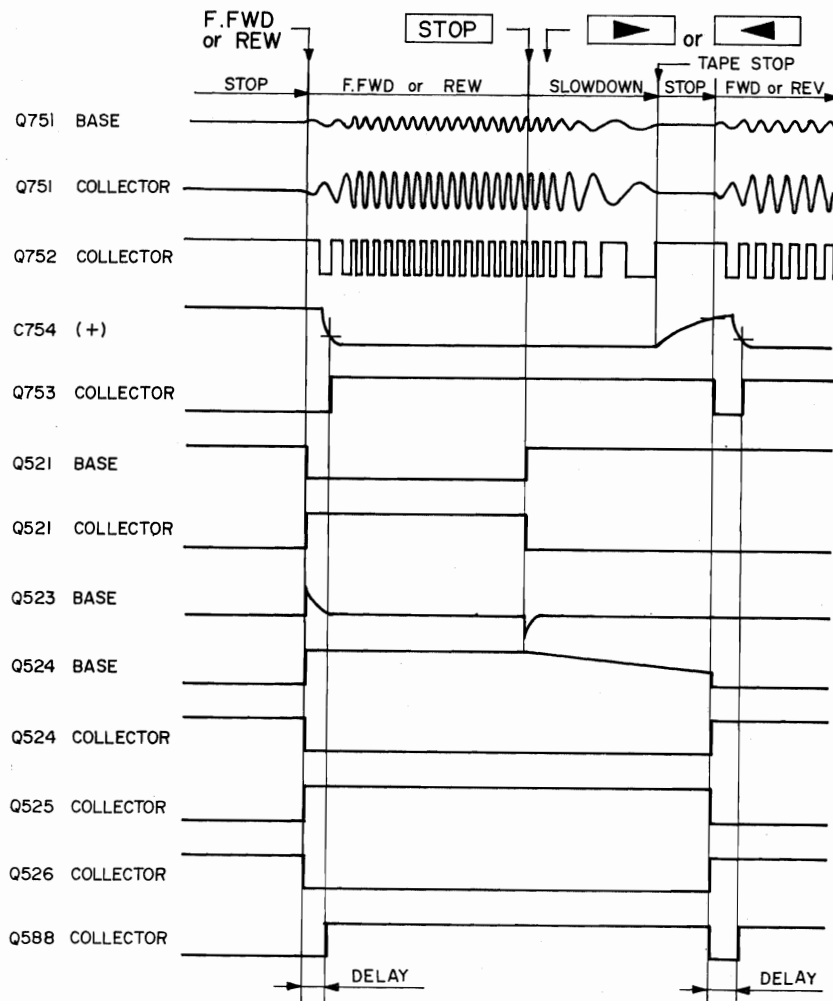

Fig. 23

3 REEL MOTOR DRIVE SECTION

Fig. 24 shows partial schematic for Reel Motor operations. 117 VAC power supply is used for Fast Winding mode, and 77 VAC is used for Play mode. If REEL size switch is set to SMALL for small reels (7" dia. reel), 77 VAC is applied to Reel Motors via R401 which decreases voltage.

The following explanation is for the case when the REEL size switch is set to LARGE for large reels (10-1/2" dia. reel). When in Forward Play mode, OPERATION signal L and MOTOR FLASHING signal H will be given from Control section. Since Relay K735 is operated by OPERATION signal, 77 VAC will be fed through R403 to right reel motor, and through R402 to left Reel Motor. At this time, Relay K734 is ON for a short while through MOTOR FLASHING signal, so that during that time, 77 VAC is directly applied to right Reel Motor. By means of this FLASHING function, motor torque at the moment of motor starting is increased to improve acceleration of Motor. When in Reverse Play mode, OPERATION and REV signals will both be L, and FLASHING signal H. As Relay

K731 is energized by REV signal, 77 VAC will be supplied through R402 to right Reel Motor, and through R403 to left Reel Motor. In other words, torque relationship between left and right reel motors is inverted from that of Forward Play mode. When changing Forward Play to Reverse Play, or Reverse Play to Forward Play, deck will be momentarily stopped, then will be changed to next operation. Also MOTOR FLASHING signal is momentarily returned to L, then after approx. 0.5 sec. it goes to H. Consequently, when changing from Forward (or Reverse) Play to Reverse (or Forward) Play, Reel Motor will be accelerated the same as when changing from STOP to Forward (or Reverse) Play. When in Fast Forward mode, F. FWD signal will go to L, thereby activating K733. 117 VAC is directly applied to right Reel Motor, and to left Reel Motor, 117 VAC is supplied via R404 which reduces the voltage. When in Rewind mode, REW signal will go L and will operate K732. The result will be that 117 VAC is fed to left Reel Motor and voltage for back tension is supplied to right Reel Motor.

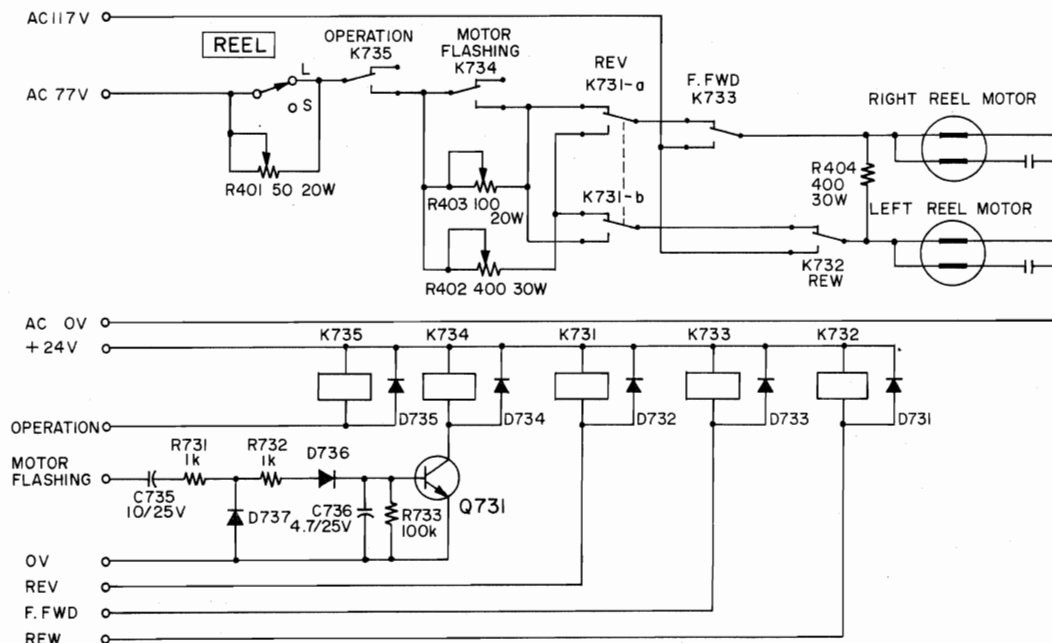

Fig. 24

4 POWER SUPPLY CIRCUIT (Refer to Power Supply circuit in supplied schematics)

(1) +7V POWER SUPPLY FOR LAMP

AC input voltage is half-wave rectified by D755 then, is filtered by C759.

(2) +24V POWER SUPPLY FOR AMPLIFIER

AC input voltage is bridge rectified by D751, is filtered by C760, then is stabilized by power supply IC U751 in order.

(3) +24V POWER SUPPLY FOR CONTROL AND FOR CAPSTAN MOTOR

AC input voltage is rectified by D753 and D754, is filtered by C765 and is stabilized by power supply IC U752.

This power supply is directly fed to Control Amplifier, while it is applied to Capstan Motor via Q756. Base of Q756 is connected to MOTOR STOP signal via R761, and when both Tension Arms are dropped downward, MOTOR STOP signal will be H to stop motor rotation.

(4) POWER SUPPLY FOR SOLENOIDS

Voltages of +24V and +48V are obtained as Power Supply for Solenoids making use of Full Wave Rectifier circuit and center tap of Power Transformer. When BRAKE SOL. FLASHING signal arrives, it will flow through C751, R754, R757 and D763 in order and then will enter into base of Q754. Accordingly, when Q754 is switched ON, Q755 will be biased in forward direction, thus it will go into conduction. +48V is applied to Solenoids for approx. 0.3 sec., then after charging of C751 is finished, Q754 and Q755 will go to OFF states, and as a result +24V will be supplied via D756 to the solenoids. Also +24V of Anode side of D756 is supplied to Lifter Solenoid which does not need Flashing function.

5 SPEED CHANGE AND REEL SIZE CHANGE CIRCUIT (Refer to Speed Switch PC Board section in supplied schematics)

When using 10-1/2" dia. reels, higher voltage to Reel Motors can be obtained by means of by-passing the Wire-wound Resistor with S711 for voltage adjustment of Reel Motor that is being used for take-up function which depends on direction of tape movement. In such a way, take-up torques for 10-1/2" dia. reels and 7" dia. ones will be compensated respectively. Switch S712 is provided for tape speed conversion between 19 cm/s and 9.5 cm/s, and it works to change Capstan Motor speed, and also simultaneously to change Amplifier Equalizer Changing signal and voltage for Bias Oscillator.

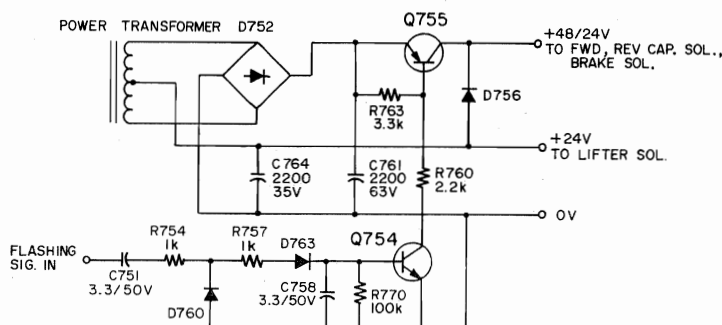

Fig. 25

AMPLIFIER CIRCUIT DESCRIPTION

The amplifier section uses an operational amplifier IC. The special features of it are effectively used to form a well designed circuit.

The stability and high performance of the operational amplifiers used up to this time have been proven by their use in existing analog computers and other equipment.

The A-6600 has been developed for audio use by employing the operational amplifier as a central part. Our company selected this component.

The features of each circuit of this amplifier will be explained later.

Up to now, our company's existing decks had no OUTPUT switch TRIM or CAL controls. Heretofore, when the output level was too low, the OUTPUT control was moved to adjust for a suitable level. But when the OUTPUT control was moved from the calibrated position the VU meter would indicate a different level than was actually recorded on the tape. This would result in an inconvenient situation. In the A-6600, in order to resolve this inconvenience, A CAL switch position has been added to the MONITOR switch so that even if the OUTPUT control is moved the VU meter indication will not change. Due to this, when the MONITOR switch is in CAL position, normally the VU meter will indicate the level of the signal that is recorded on the tape.

Also the TRIM control can be used to compensate for the slight differences in levels on playback tape.

The preceding is a summary of the new features. Next, special features and operation of other circuits, etc. will be explained.

Almost without fail explanation will be for the L channel only.

Amplifier is constructed as shown in Fig. 1.

AMPLIFIER BLOCK DIAGRAM

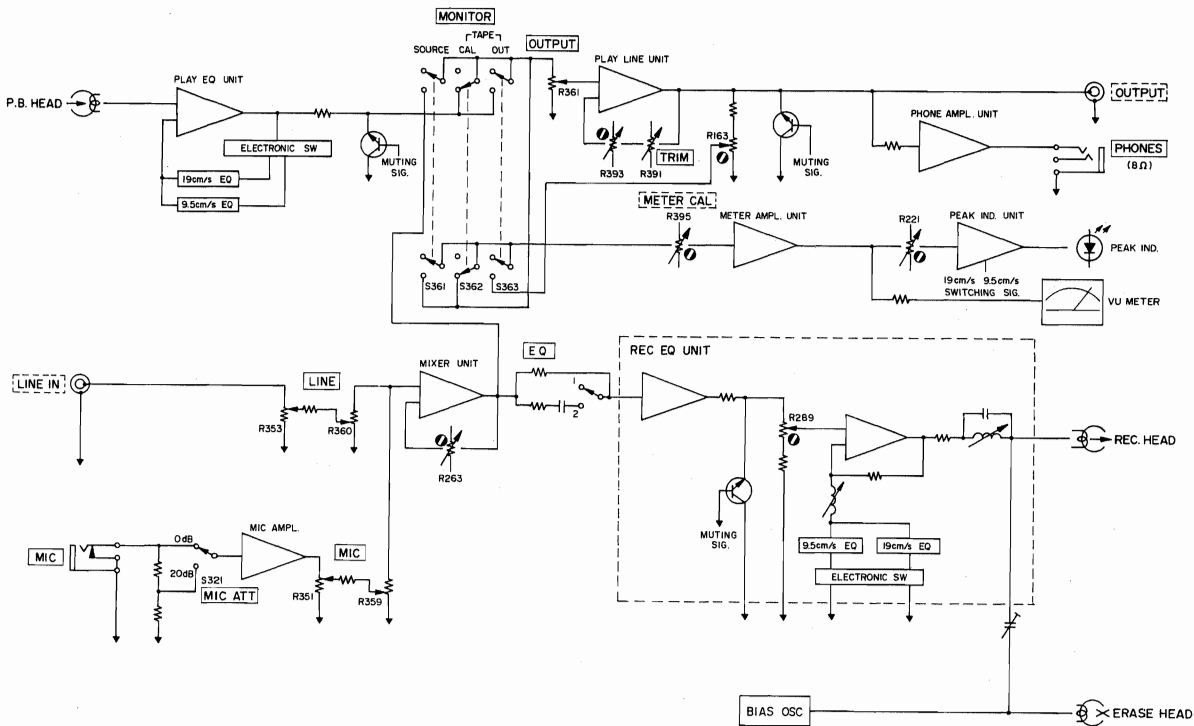

Fig. 1

1. PLAY EQ UNIT

Herein, explanations of the changes in the equalization depending on the tape speed and performed by the electronics switches and the Muting circuit are given.

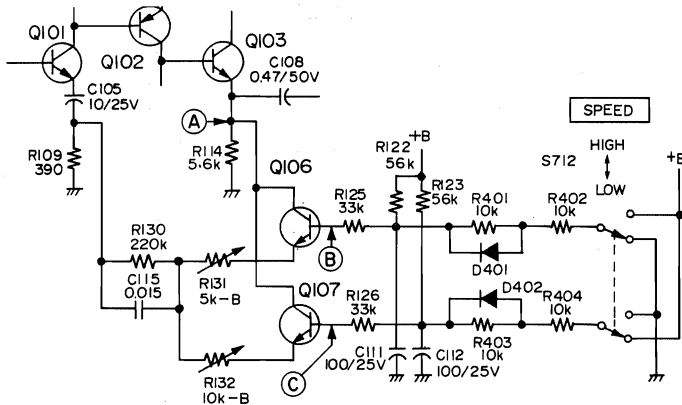

Fig. 2

1-1 EQ SWITCH

The playback equalization time constants at 19 cm/s (7-1/2 ips) are $3180 \mu\text{s} + 50 \mu\text{s}$ and at 9.5 cm/s (3-3/4 ips) are $3180 \mu\text{s} + 90 \mu\text{s}$. Q106 and Q107 make up an electronic switch which is used to select the resistors R131 or R132 for the high region time constant of $50 \mu\text{s}$.

Now as shown in Fig. 2, the potential at point (A) is approx. 12 V, point (B) is approx. 10 V and point (C) is approx. 12.6 V. With these conditions the collector-emitter junction of Q107 has a low resistance. High region feedback current passes through R132 and is added in. By changing the SPEED switch. (S712), conducting condition of Q106 and Q107 are changed and the feedback circuit is formed by R131.

In this switching circuit, by using the transistor base current to control the resistance across the collector-emitter junction, a small current (compared to that which is necessary for mechanical switching) is used for control, R122, R123, C111, C112, D401, D402, etc., are used to reduce click noise during switching and to insure stable switch operation.

1-2 MUTING UNIT

This circuit, in addition to eliminating drop-outs and level wavering during tape acceleration in Play mode, also eliminates unwanted noise during any mode other than Play mode.

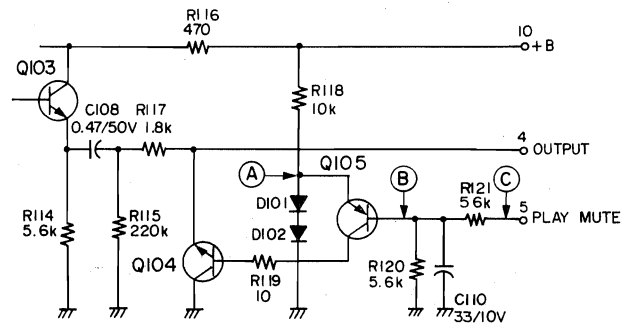

Fig. 3 (On play EQ unit)

Point (A) of Fig. 3 requires a voltage potential of 2 times the forward direction voltage drop of the silicon diodes (D101, D102) of 0.6 V (total 1.3 V) to maintain its state. This is the emitter voltage to stabilize Q105 and opposes the Muting Signal. This signal stabilizes the Muting signal during repeated ON/OFF operations. When point (C) is approx 0 V, the base current of Q105 flows from the emitter through R120 and Q105 goes ON. The collector current of Q105 becomes the base current of Q104 and Q104 also goes ON. The Playback output signal depends on the ratio of the resistance of R117 and the impedance of Q104. (When Q104 is ON, $Z \cong 0$ ohms). At this time Muting is ON. (Output signal is shorted to ground). Then when approx. +24 V is supplied to point (C), the voltage at point (B) (V point B $\cong \frac{24 \text{ V} \times R120}{R120 + R121}$) is applied. Since the voltage potential is high, Q105 goes OFF. Then Q104 also goes OFF and muting is released. C110 opposes the muting signal so that the muting effect change will occur smoothly. Also it serves to make muting OFF occur slowly and muting ON occur quickly.

2. PLAY LINE UNIT

The front stage of this circuit uses an operational amplifier and therefore the operational amplifier and its basic usage will be explained.

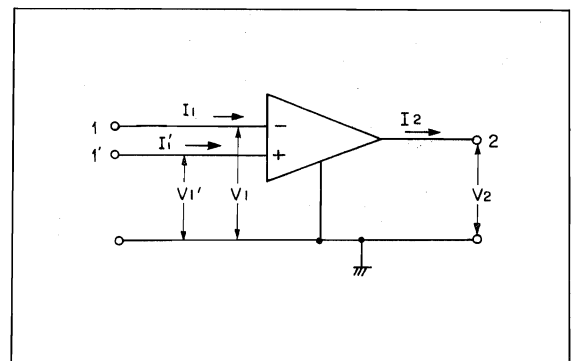

Fig. 4 Operational Ampli.

2-1 STANDARD OPERATIONAL AMPLIFIER

The standard operational amplifier, as shown in Fig. 4, has balanced differential input terminals 1, 1' (referenced to ground) and single ended output terminal 2.

2-2 IDEAL RESPONSE

Ideally the response is as shown in (a) to (d), but of course, usually all of these response characteristics are not completely achieved. Usually these limits present no problem.

(a) Voltage Gain:

$$\text{Differential gain} = -A_d = V_2 / (V_1 - V_1'), A_d = \infty \text{ (inf)}$$

$$\text{Phase gain} = A_c = V_2 / \frac{(V_1 + V_1')}{2}, A_c = 0$$

(b) Input Response: Input Current $I_1 = I_1' = 0$

(c) Output Response: Input impedance = ∞ (inf) Output Impedance = 0

(d) Frequency Response:

$$\text{Amplifier Frequency Band} = \infty \text{ (inf)}$$

$$\text{Response time} = 0$$

Above explanation was based on ideal response. Basic usage (application) will now be explained.

2-3 INVERTING AMPLIFIER

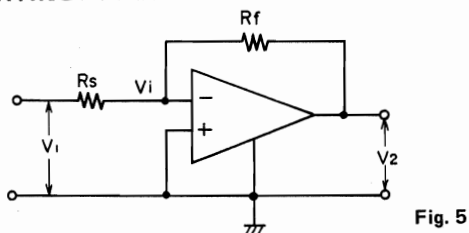

Fig. 5

If the gain of the circuit in Fig. 5, $A_d = \infty$ and if the input impedance = ∞ (inf),

$$V_i = V_2 / -A_d \dots \dots \dots (A)$$

$$V_i = V_1 \cdot \frac{R_f}{R_s + R_f} + V_2 \cdot \frac{R_s}{R_f + R_f} \dots \dots \dots (B)$$

From formula (A) and (B)

$$V_2 = V_1 \cdot \frac{-\frac{R_f}{R_s + R_f} A_d}{1 + \frac{R_s}{R_s + R_f} A_d} \dots \dots \dots (C)$$

From formula (C), if $A_d = \infty$ (inf)

$$V_2 = V_1 \cdot \frac{-R_f}{R_s}, G = \frac{V_2}{V_1} = \frac{-R_f}{R_s}$$

On the one hand if A_d approaches, ∞ from formula (A) we get V_1 goes to 0. Therefore, even if the input impedance of the operational amplifier is limited, V_1 will be 0 and input current to the operational amplifier will not flow. That is, the junction of R_s and R_f of the inverting amplifier can be considered as ground. This will be an imaginary ground. Also, since $V_1 = 0$ V, the input current of the amplifier circuit all flows through R_s . In other words, the input impedance $Z = R_s$.

2-4 NON-INVERTING AMPLIFIER

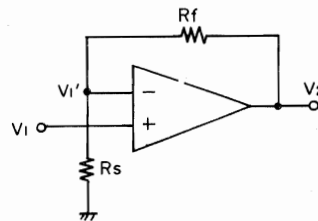

Fig. 6

Refer to Fig. 6. When $V_1 = V_1'$

$$V_1' = V_2 \cdot \frac{R_s}{R_s + R_f}, \frac{V_2}{V_1} = G = \frac{R_s + R_f}{R_s} = 1 + \frac{R_f}{R_s}$$

Then: $Z_{in} = \infty$

2-5 PLAY LINE UNIT -FRONT STAGE-

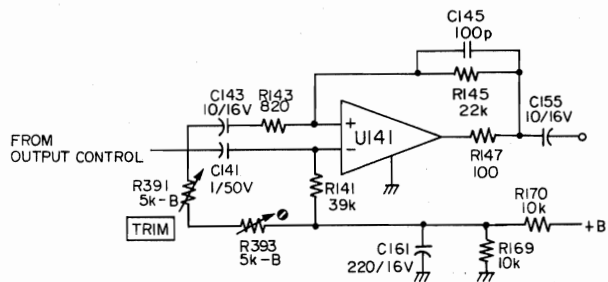

Fig. 7

If we look at Fig. 7 as a DC circuit, since one input is cut off by C143, the R_s of the non-inverting amplifier = ∞ . That is, $G = 1$. Then, the voltage $+B \cdot R_{169} / (R_{170} + R_{169})$ is applied at the input and output terminals. Then, if $R_{170} = R_{169}$, the voltage $V_{cc}/2$ will appear at the input and output terminals. This voltage potential becomes the bias which is used to amplify the AC signal. Then, looking at the circuit in terms of AC, $G = 1 + \frac{R_{145}}{R_{145} + R_{348} + R_{391}} \cdot R_{393}$ is used for gain adjustment and R391 is used as a level trimmer (TRIM).

C145 gives -6 dB/octave (at the frequency determined by $\frac{1}{2\pi \cdot C_{145} \cdot R_{145}}$) high band reduction to reduce unwanted noise.

The purpose of R147 is to provide protection in case the output terminals are shorted.

2-6 PLAY LINE UNIT -BACK STAGE-

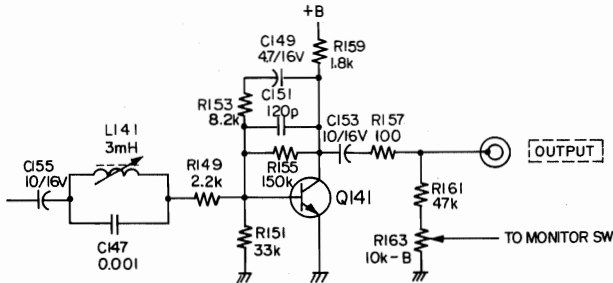

Fig. 8

Fig. 8 is a self-biased, one transistor amplifier which has a buffer to the output terminals. As AC feedback becomes deeper, output impedance becomes lower and distortion is suppressed. The effect of the bias trap toward lowering the input impedance is very great due to the parallel resonance of L141 and C147.

3. PHONE AMPL. UNIT

This circuit supplies 1 mW into 8 ohms. Also, this circuit has a fixed electric current characteristic and it will supply the same sound level even if the headphone load impedance varies.

4. METER AMPL. UNIT

This circuit uses a linear IC for wide range and low distortion. It drives both the VU meters and the peak indicators.

5. PEAK IND. UNIT

Basically this is a mono-stable multivibrator type indicator. This circuit changes the ignition level depending on the tape speed.

6. MIC AMPL. UNIT

This amplifier is a high stability, low distortion, high dynamic range, low noise, 2-stage, directly connected amplifier. The input has a 20 dB pad to reduce the microphone signal by 20 dB.

7. MIXER UNIT

Basically, the circuit is constructed as shown in Fig. 9.

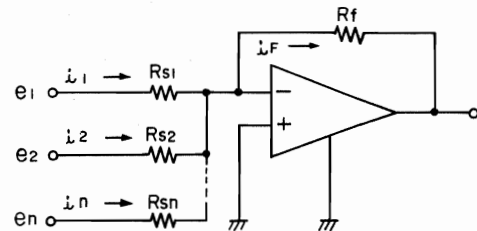

Fig. 9

Fig. 9 is an inverting amplifier since the minus (-) terminal has an imaginary ground. The input impedance seen from e_1 , Z_{in1} , and the input impedance seen from e_2 , Z_{in2} , are $Z_{in1} = R_{s1}$ and $Z_{in2} = R_{s2}$. That is, since the gain for each input is determined by R_s only, there is no mutual interaction between each input.

Input current i_1 and i_2 : $i_1 = \frac{e_1}{R_{s1}}$, $i_2 = \frac{e_2}{R_{s2}}$, $i_n = \frac{e_n}{R_{sn}}$

$$i_f = i_1 + i_2 + \dots + i_n$$

Therefore: $V_o = -R_f \cdot i_f$

(but, minus (-) terminal is imaginary ground)

$$V_o = \left(-\frac{R_f}{R_{s1}} e_1 + \frac{R_f}{R_{s2}} e_2 + \dots + \frac{R_f}{R_{sn}} e_n \right)$$

That is to say, that the gain of each input signal is independently determined by input resistor R_s which allows (proper) mixing.

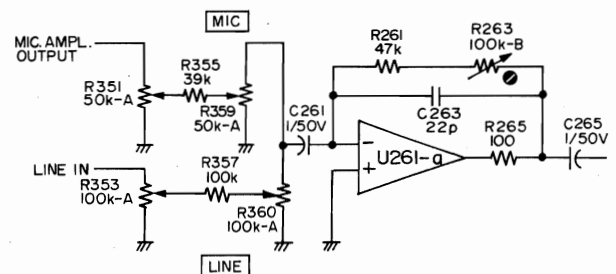

Fig. 10

To restrict the gain of each input to 0, R_s must be increased towards ∞ . Actually as shown in Fig. 10, R_s is determined so that e can be changed. For the inverting amplifier shown in Fig. 10, you can see that $R_f = R_{261} + R_{263}$ and $R_s = R_{359}$ and R_{360} . In this way, after setting the LINE and MIC controls carefully for each input, L and R levels, the MASTER control can be used to fade the L and R inputs at the same time.

8. RECORD AMPLIFIER

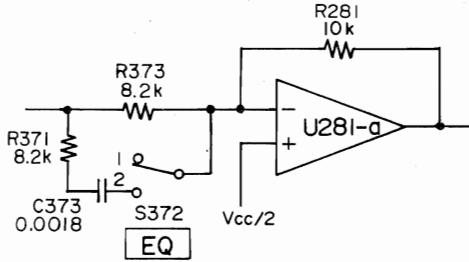

Fig. 11

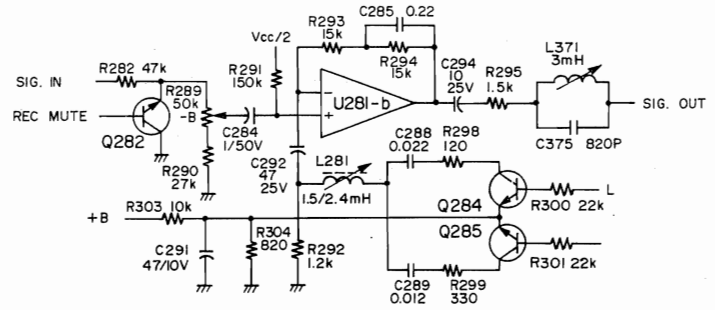

Fig. 13 (On play EQ unit)

8-1 RECORD AMPLIFIER – FRONT STAGE –

Fig. 11 is an inverting amplifier for the purpose of changing the EQ according to the type of tape. Characteristics are shown in Fig. 12.

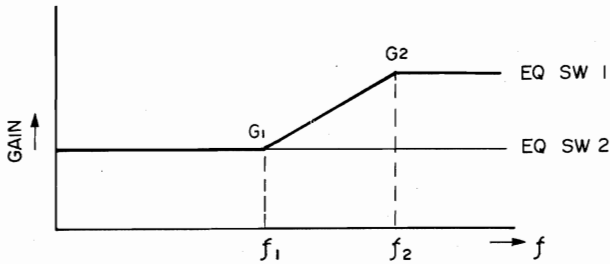

Fig. 12

$$G_1 = \frac{R_{281}}{R_{373}} \quad f_1 = \frac{1}{2\pi \cdot C_{373} \cdot R_{371}}$$

$$G_2 = \frac{R_{281}}{\left(\frac{R_{373} \cdot R_{371}}{R_{373} + R_{371}}\right)} \quad f_2 = \frac{1}{2\pi C_{373} \cdot \left(\frac{R_{371} \cdot R_{373}}{R_{371} + R_{373}}\right)}$$

This circuit boosts the signals over 10 kHz by approx 3 dB.

8-2 RECORD EQ UNIT

Q282 shown in Fig. 13 is in the record muting circuit and works during auto spacing, etc. Circuit operation is the same as Playback muting.

C285 is for low band compensation. L281, C288, etc. are for high band peaking. Record EQ also receives a signal from the speed switch to change the electronic switch made up of Q284 and Q285.

R303, R304 provide +3 V bias to the emitter of Q284 and Q285 to make sure that they go OFF.

9. MUTING UNIT (POWER)

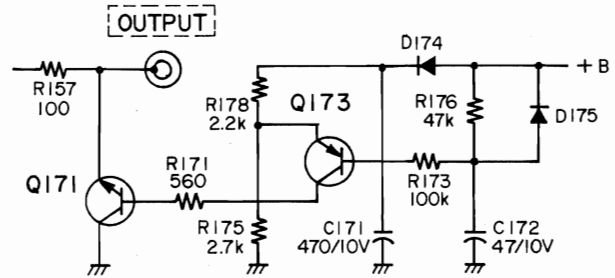

Fig. 14

In Fig. 14, the approx. +7 V is quickly applied to use as power muting when power is turned ON or OFF.

This muting is applied to the output terminals during power ON/OFF to prevent unwanted noise.

Now when power is applied C171 charges through D174 and a certain potential is applied to the emitter of Q173 but since the charge time of C172 is long, the base potential of Q173 is lower than the emitter and Q173 turns ON. At that time muting is applied. After several seconds, when each amplifier settles down to normal operation, the charge voltage on C172 increases and Q173 goes OFF and muting is released. Then, when current is cut off and approx. +7 V decreases by a large amount, the electric charge on C172 discharges quickly through D175. Since one discharge path for C171 through D174 is slow, during this interval the emitter potential is higher than the base potential, Q173 goes ON and also Q171 goes ON and muting goes on.

Refer to next page Fig. 15. Timing Chart.

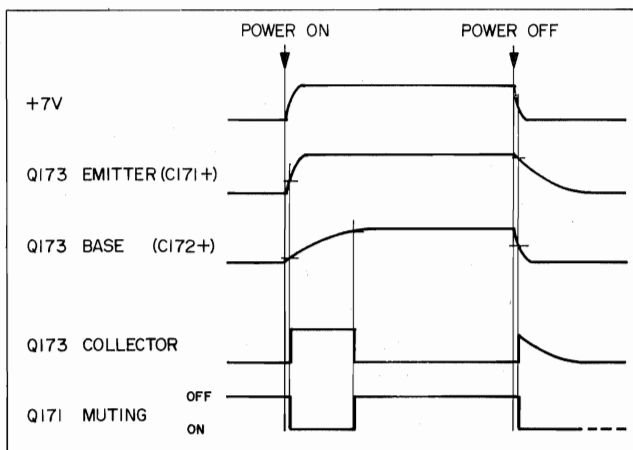

Fig. 15

10. BIAS OSC UNIT

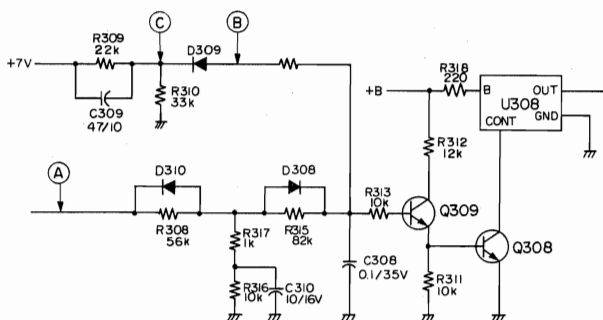

Fig. 16

Fig. 16 is the Bias Oscillator Circuit. With approx. 24 V applied to point (A), due to the ratio of R308 and R317, point (B) will have a lower potential. Then, after a short period of time, when C310 which is connected across R316 finishes charging, the potential at point (B) rises. Current flow through D308 and R313 begins and the Darlington circuit of Q309 and Q308 begins to close. Then, this smooth rise characteristic saturates and oscillation continues.

The reason the start of oscillation is delayed by C310 is to delay the start of recording until after the record relay energizes in order to reduce click noise. Then when point (A) goes to 0 V, the charge on C310 discharges through D310. Also the charge on C308 discharges slowly through R315. Then the Bias Oscillator output goes to 0 V before the Record Relay is released.

In order to reduce the noise recorded on the tape when power is cut off during recording the circuit consisting of R309, R310, C309 and D309 which normally supplies approx. +7 V is used. During the discharge of C309, point (C) becomes a negative voltage which is used to quickly cut-off the oscillator signal.

11. BASIC TIMING CHART

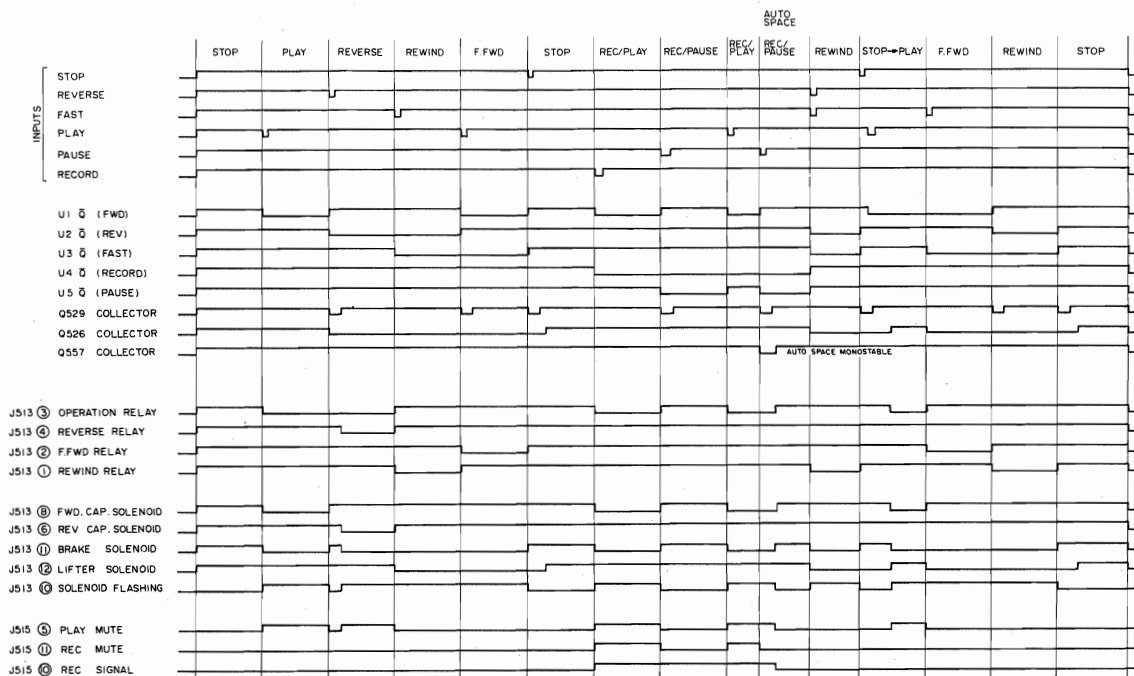

T-995

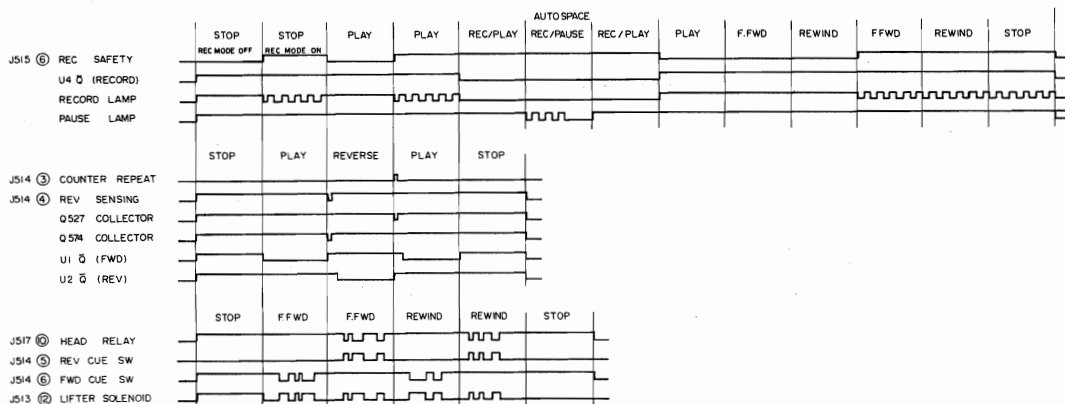

T-996

Fig. 17

AN AFTERWORD

This deck uses various methods to reduce each type of click noise. Especially at interstage connections, low noise, low leakage current chemical capacitors are effectively arranged to obtain low values of click noise.

A-6600

Stereo Tape Deck

TEAC

TEAC CORPORATION

3-7-3, NAKA-CHO, MUSASHINO, TOKYO PHONE: (0422) 53-1111

TEAC CORPORATION OF AMERICA

7733 TELEGRAPH ROAD, MONTEBELLO, CALIFORNIA 90640 PHONE: (213) 726-0303

PRINTED IN JAPAN 0478 SYU22.0 D-2803A

TEAC®

PARTS LIST

A-6600

Stereo Tape Deck



TABLE OF CONTENTS

1. EXPLODED VIEWS AND PARTS LISTS	2~11
INCLUDED ACCESSORIES	3
2. TRANSISTOR SUBSTITUTION CHART	11
3. PC BOARD SECTION (Diagram and Parts List)	
3-1. PLAYBACK EQ PC BOARD ASSY	12, 23
3-2. PLAYBACK LINE PC BOARD ASSY	12, 23
3-3. MUTING PC BOARD ASSY	13, 24
3-4. PHONE AMPL. PC BOARD ASSY	13, 24
3-5. METER AMPL. PC BOARD ASSY	14, 24
3-6. PEAK INDICATOR PC BOARD ASSY	14, 25
3-7. MIXER PC BOARD ASSY	15, 25
3-8. REC EQ PC BOARD ASSY	15, 25
3-9. BIAS OSCILLATOR PC BOARD ASSY	16, 26
3-10. MIC AMPL. PC BOARD ASSY	16, 26
3-11. MIXING VAR. RES. PC BOARD ASSY	17, 27
3-12. MONITOR SWITCH PC BOARD ASSY	17, 27
3-13. REC SWITCH PC BOARD ASSY	18, 27
3-14. TRIM VAR. RES. PC BOARD ASSY	18, 27
3-15. METER CAL PC BOARD	18, 27
3-16. MOTHER PC BOARD ASSY	19, 27
3-17. CONTROL PC BOARD ASSY B	20, 28
3-18. POWER SUPPLY PC BOARD ASSY	21, 29
3-19. MOTOR RELAY PC BOARD ASSY	22, 30
3-20. TENSION SERVO SENSOR PC BOARD ASSY	22, 30
ASSEMBLING HARDWARE CODING LIST	31

PARTS ORDERING INFORMATION

Spare parts are available through your nearest TEAC Authorized Service Center or directly from the TEAC office, the address of which is written on the back cover. When ordering parts always include the following information:

- | | |
|--------------|--------------------|
| 1. MODEL | 4. DESCRIPTION |
| 2. REF. NO. | 5. UNIT SERIAL NO. |
| 3. PARTS NO. | 6. MANUAL CODE NO. |

NOTICE REGARDING PARTS ORDERS

1. Do not order by only REF. NO.
2. In some instances, individual minor parts are not available. In such a case, the entire assembly including the part requested will be sent to you.
3. Parts are identical between the different models with the exceptions as coded by the designations in the REMARKS column.
4. PC Boards shown viewed from foil side.
5. Parts marked with * require longer delivery time than regular parts.

1. EXPLODED VIEWS AND PARTS LISTS

EXPLODED VIEW-1

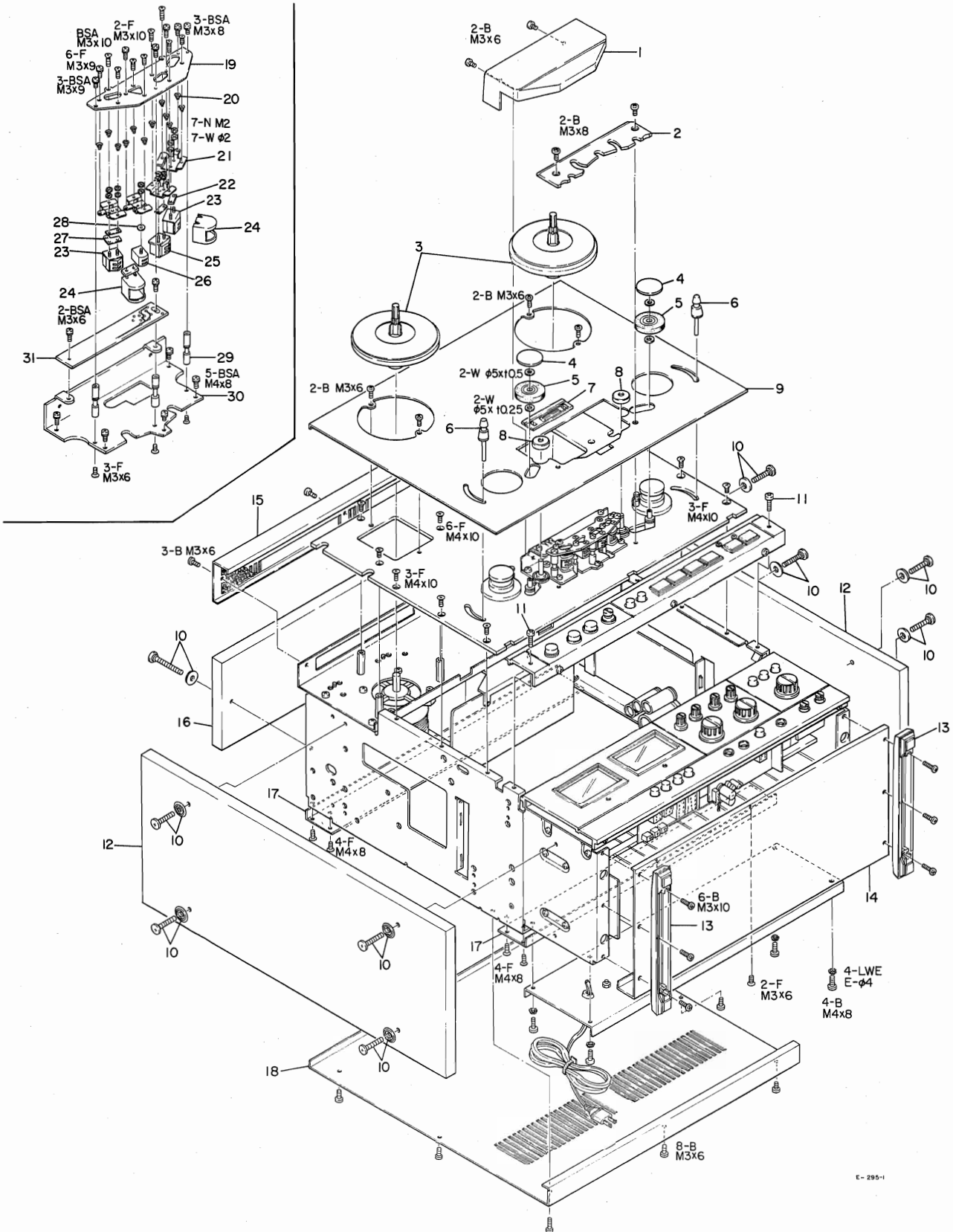

E-295-1

REF. NO.	PARTS NO.	DESCRIPTION	REMARKS
1 - 1	*55031170	Head Housing	
1 - 2	*55330930	Plate, Housing Base	
1 - 3	55044441	Reel Table Assy	
1 - 4	55405180	Cap, Pinch Roller	
1 - 5	55002100	Pinch Roller	
1 - 6	55044451	Guide Assy, Tension	
1 - 7	*55343780	Cover, Index Counter, A	
1 - 8	*50123971	Cap, Dust; $\phi 6$	
1 - 9	*55521631	Panel, Trim	
1 - 10	*55045490	Screw Assy, Board	
1 - 11	55810510	Screw, Trim	
1 - 12	*55430220	Board, Side; A	
1 - 13	*55044931	Leg Assy, Case	
1 - 14	*55044531	Cover Assy, Bottom	
1 - 15	*55044520	Grille Assy	
1 - 16	*55430200	Board, Top; A	
1 - 17	*55531541	Angle, Rear Cover	
1 - 18	*55531600	Cover, Rear; A	
1 - 19	*55531490	Plate, Head Base; A	
1 - 20	50220500	Spring, B	
1 - 21	*50134371	Plate, Head	
1 - 22	*55501511	Spacer, Head; A	
1 - 23	50664550	Head, Playback (4T-2CH)	
1 - 24	*55549490	Head Shield, B	
1 - 25	50664540	Head, Record (4T-2CH)	
1 - 26	50663090	Head, Erase	
1 - 27	*55551790	Plate, Grounding	
1 - 28	*50136540	Spacer, Erase Head	
1 - 29	55445770	Guide, Tape	
1 - 30	*55531471	Plate, Head Housing; A	
1 - 31	*51684780	PC Board Assy, Head; B	
	51674780	PC Board	Part of 1 - 31
	50611210	Relay, Head	Part of 1 - 31
	50571460	Carbon Res. 470k ohm 1/4W 5% (R801, R802)	Part of 1 - 31
	50570580	Carbon Res. 100 ohm 1/4W 5% (R803)	Part of 1 - 31
	51430890	Diode W03C (D801)	Part of 1 - 31
	50554490	Cap. Elec. 47 mfd 25V (C801)	Part of 1 - 31

INCLUDED ACCESSORIES

REF. NO.	PARTS NO.	DESCRIPTION	REMARKS
	51280010	Cords, Input-output Connection 2 used	
	RE-1002	Empty Reel, 10 inch	
	55980250	Reel Adapter, Clamp (TZ-612) 2 used	
	50291860	Oil and Applicator	
	50629620	Splicing Tape	
	50272880	Sensing Foil	
	51013371	Information Supplement	
	51015010	A-6600 Owner's Manual	GENERAL EXPORT
	51014990	A-6600 Owner's Manual	U.S.A., CANADA

EXPLODED VIEW-2

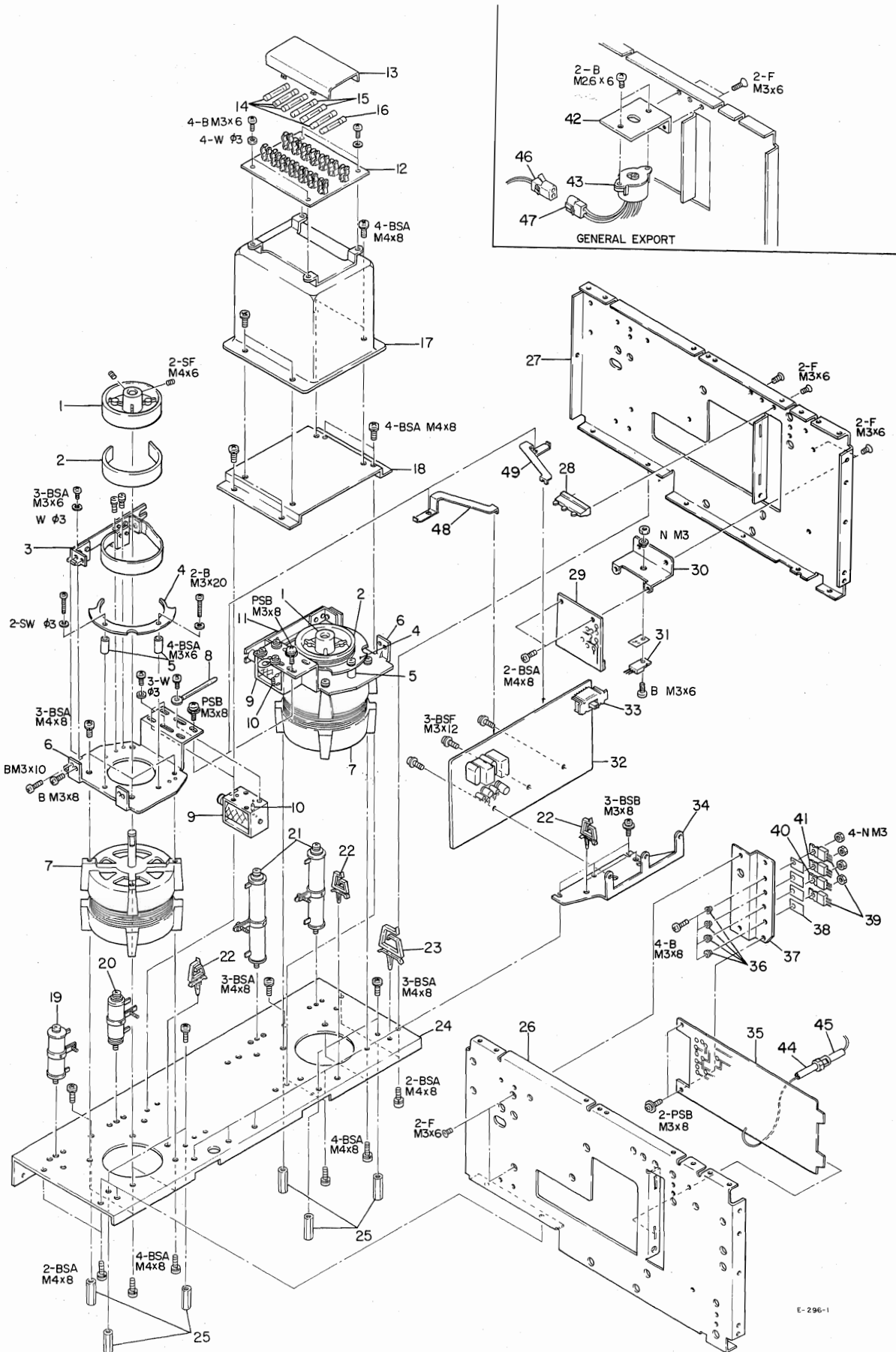

E-296-1

REF. NO.	PARTS NO.	DESCRIPTION	REMARKS
2 - 1	50173571	Drum, Brake	
2 - 2	55552740	Shoe, Brake	
2 - 3	50173393	Band Assy, Brake; R	
2 - 4	*50173481	Retainer, Brake	
2 - 5	*50173490	Spacer, Brake Retainer	
2 - 6	*50173601	Plate, Brake Band Assy	
2 - 7	71041071	Motor, Reel	
2 - 8	*55810380	Retainer, Cord; A	
2 - 9	51630250	Solenoid, Brake	
2 - 10	51430890	Diode, W03C	
2 - 11	50173333	Band Assy, Brake; L	
2 - 12	*51684762	PC Board Assy, FUSE	
	51674762	PC Board	Part of 2 - 12
2 - 13	55344560	Cover, Fuse	Part of 2 - 12
2 - 14	50411140	Fuse, 250V 2A	GENERAL EXPORT
	50411440	Fuse, 250V 2A	U.S.A., CANADA
2 - 15	50411010	Fuse, 250V 1A	GENERAL EXPORT
	50411450	Fuse, 250V 1A	U.S.A., CANADA
2 - 16	51422110	Fuse, 250V 3A	GENERAL EXPORT
	51420910	Fuse, 250V 3A	U.S.A., CANADA
2 - 17	*51521490	Transformer, Power	GENERAL EXPORT
	*51521180	Transformer, Power	U.S.A.
	*51521500	Transformer, Power	CANADA
2 - 18	*55549990	Bracket, Power Transformer	
2 - 19	50522211	Resistor, Wire Wound 50 ohm 20HA	
2 - 20	50524201	Resistor, Wire Wound 100 ohm 20HA	
2 - 21	50524070	Resistor, Wire Wound 400 ohm 30HA	
2 - 22	*55344880	Retainer, Cord; H	
2 - 23	*55344930	Retainer, Cord; I	
2 - 24	*55521921	Chassis, Reel Motor	
2 - 25	*55449170	Stud, Reel Motor	
2 - 26	*55521980	Chassis, Side; R	
2 - 27	*55521970	Chassis, Side; L	
2 - 28	50438490	Terminal Strip, 3P	U.S.A., CANADA
2 - 29	*51685662	PC Board Assy, CAPSTAN SERVO	
2 - 30	*55551760	Heat Sink, OBD	Part of 2 - 29
2 - 31	*51450750	Transistor, 2SD235 (O)	Part of 2 - 29
2 - 32	*51684751	PC Board Assy, MOTOR RELAY, B	GENERAL EXPORT
	*51686210	PC Board Assy, MOTOR RELAY, C	U.S.A., CANADA
	50444560	Switch, Slide; 6P	GENERAL EXPORT
2 - 34	*55549960	Bracket, PC Board	
2 - 35	*51686230	PC Board Assy, POWER SUPPLY	
2 - 36	*50332950	Washer, Insulating	Part of 2 - 35
2 - 37	*55550140	Heat Sink, A	Part of 2 - 35
2 - 38	*50332910	Sheet, Insulating	Part of 2 - 35
2 - 39	*50425460	Transistor, 2SA490(Y)	Part of 2 - 35
2 - 40	*51470270	IC, μ A7824CU	Part of 2 - 35
2 - 41	*51470260	IC, μ A78M24CU	Part of 2 - 35
2 - 42	*55552210	Bracket, Voltage Selector	GENERAL EXPORT
2 - 43	*51310070	Voltage Selector	GENERAL EXPORT
2 - 44	*51223320	Connector Assy, 1P	Part of 1 - 35
2 - 45	51223310	Connector Assy, Plug; 1P	Part of 4 - 1
2 - 46	51220930	Connector Housing, Plug; 2P	
2 - 47	51220920	Connector Housing; Socket; 2P	
2 - 48	*55551710	Bracket, PC Board; A	
2 - 49	*55551720	Bracket, PC Board; B	

REF. NO.	PARTS NO.	DESCRIPTION	REMARKS
3 - 1	55241070	Spring, Lifter Return	
3 - 2	*55550090	Plate, Link	
3 - 3	*55045060	Plate Assy, Lifter	
3 - 4	*55044190	Plate Assy, Slide	
3 - 5	55445810	Collar, Slide Plate	
3 - 6	*55044200	Arm Assy, Lifter	
3 - 7	71050122	Motor Assy, Capstan; A	
3 - 8	*55549970	Plate, Capstan Motor	
3 - 9	*55446130	Stud, Capstan Motor	
3 - 10	51300030	Switch, Micro	
3 - 11	*55500251	Sheet, Insulating	
3 - 12	*55549980	Bracket, Micro Switch	
3 - 13	55241310	Spring, Tension; B	
3 - 14	*55552780	Stopper, Tension; Left	
3 - 15	*55044560	Angle Plate Assy, Thrust	
3 - 16	*50277233	Plate, Thrust	Part of 3 - 15
3 - 17	*55343630	Belt, Capstan	
3 - 18	*55331080	Flywheel, Capstan; A	
3 - 19	*50123802	Flywheel, Capstan; B	
3 - 20	*50123860	Stud, Capstan Flywheel	
3 - 21	*50142190	Plate, Arm Support	
3 - 22	50120441	Capstan Assy	
3 - 23	*55044410	Damper Assy, B; Left	
3 - 24	*55241030	Spring, Damper; Left	Part of 3 - 23
3 - 25	*55810380	Retainer, Cord; A	
3 - 26	*55446750	Stud, Retainer	
3 - 27	*55445640	Bearing Roller	
3 - 28	*55044081	Sensing Assy	
3 - 29	*55447140	Boss, Thrust	
3 - 30	*55045461	Roller Assy, Guide; D	
3 - 31	*55045082	Arm Assy, Tension; Left	
3 - 32	*55446181	Shaft, Tension Arm; A	
3 - 33	*55343680	Washer, Insulating	
3 - 34	*51684850	PC Board Assy, STOP SENSOR	
	51674850	PC Board	Part of 3 - 34
	51431050	Magnetic Resistance Element	Part of 3 - 34
3 - 35	55550320	Bracket, PC Board	
3 - 36	*55044860	Roller Base Assy, A	
3 - 37	*55343800	Collar, Insulating	
3 - 38	*55446160	Pole, Left	
3 - 39	*55446170	Pole, Right	
3 - 40	55045160	Holder Assy, Metal	
3 - 41	55044500	Roller Assy, Guide; A	
3 - 42	*55552770	Stopper, Tension; Right	
3 - 43	*55045091	Arm Assy, Tension; Right	
3 - 44	50443950	Switch, Push; DPDT	
3 - 45	*55550010	Bracket, Counter	
3 - 46	*55552050	Spacer, Push Switch	
3 - 47	55305250	Button	
3 - 48	50585150	Counter Assy	
3 - 49	*55044490	Magnet Assy	
3 - 50	55343700	Belt, Counter	
3 - 51	51630260	Solenoid, Pinch Roller; Left	
3 - 52	51430890	Diode, W03C	
3 - 53	50275690	Cushion	
3 - 54	*55549910	Stopper, Solenoid; A	
3 - 55	*50220441	Spring	
3 - 56	51630270	Solenoid, Pinch Roller; Right	
3 - 57	*55044170	Arm Assy, Roller; Left	
3 - 58	*55241000	Spring, Pressure	
3 - 59	*55044180	Arm Assy, Roller; Right	
3 - 60	*55521653	Panel, Top	

(Continued on page 11)

EXPLODED VIEW-4

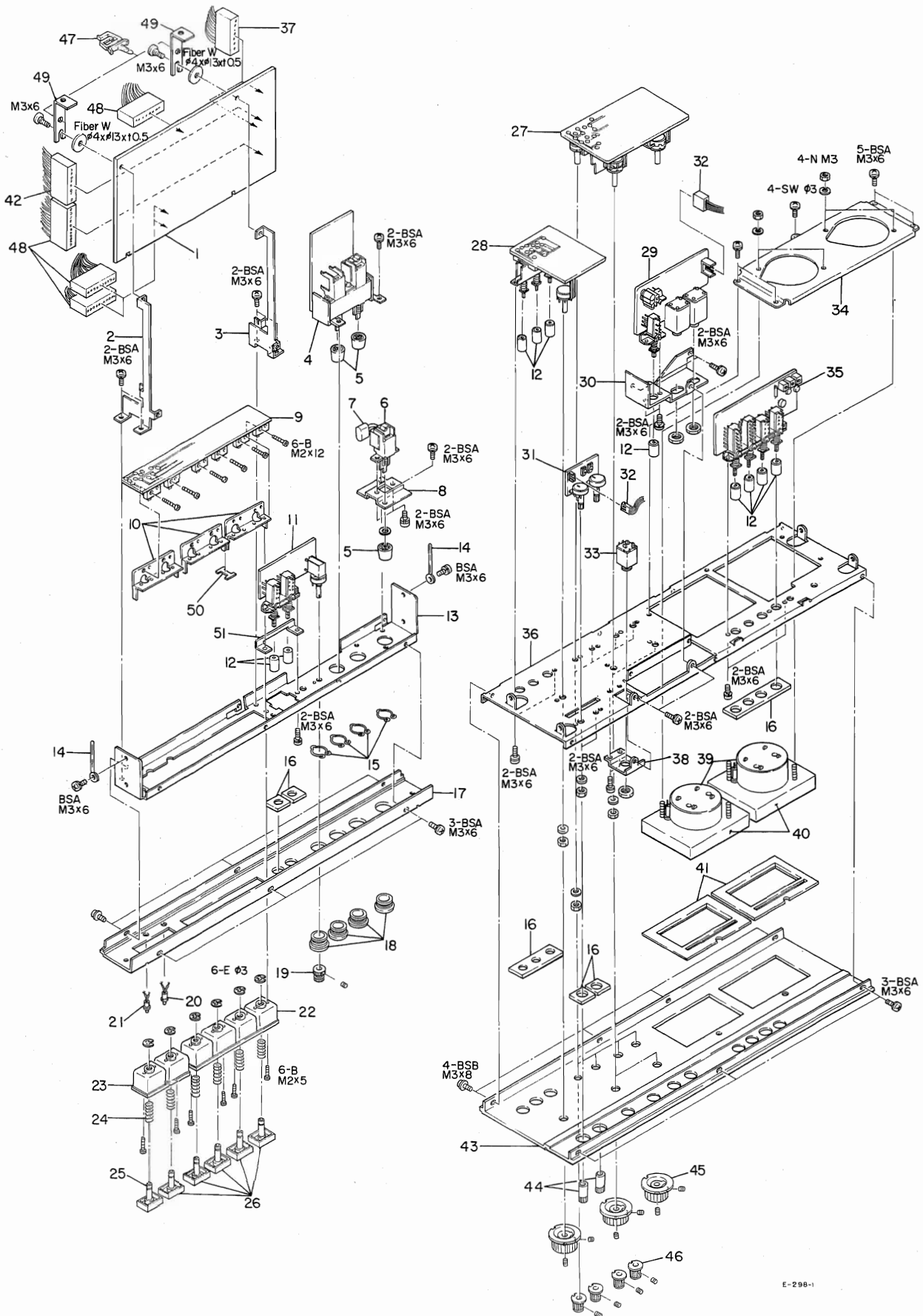

E-298-1

REF. NO.	PARTS NO.	DESCRIPTION	REMARKS
4 - 1	*51686200	PC Board Assy, CONTROL; C	
4 - 2	*55531531	Bracket, Control PC Board; R	
4 - 3	*55531521	Bracket, Control PC Board; L	
4 - 4	*51684950	PC Board Assy, Speed Switch	
	51674680	PC Board	Part of 4 - 4
	51340320	Switch, Push; 2-gang	Part of 4 - 4
	51575120	Carbon Res. 18 ohm 1/2W 5% (R711)	Part of 4 - 4
4 - 5	*55343820	Knob, B	
4 - 6	*51340590	Switch, Power	GENERAL EXPORT
	*51340210	Switch, Power	U.S.A., CANADA
4 - 7	50529060	Spark Killer, 0.033 mfd + 120 ohm 400V AC	GENERAL EXPORT, U.S.A.
	50529110	Spark Killer, 0.033 mfd + 120 ohm 250V	CANADA
4 - 8	*55550030	Bracket, Power Switch	
4 - 9	*51684820	PC Board Assy, MICRO SWITCH	
	51674820	PC Board	Part of 4 - 9
	50446610	Switch, Micro	Part of 4 - 9
4 - 10	*55549930	Bracket, Button	
4 - 11	*51684811	PC Board Assy, CUE SWITCH	
	51674811	PC Board	Part of 4 - 11
	51501940	Var. Res., 50k ohm - B (w/Switch)	Part of 4 - 11
	51340290	Switch, Push; B	Part of 4 - 11
4 - 12	*55343830	Knob, B	
4 - 13	*55521861	Chassis, Control	
4 - 14	*55810380	Retainer, Cord; A	
4 - 15	*55240870	Retaining Ring, Escutcheon	
4 - 16	*55343720	Escutcheon, Cue	
4 - 17	*55021560	Panel, Control	
4 - 18	*55343670	Escutcheon	
4 - 19	55440380	Knob, Pitch Control	
4 - 20	51430540	LED (Green)	
4 - 21	51430530	LED (Red)	
4 - 22	*55330990	Escutcheon, 4-gang	
4 - 23	*55343650	Escutcheon, 2-gang	
4 - 24	*55241110	Spring	
4 - 25	*55044091	Button Assy, A	
4 - 26	*55044101	Button Assy, B	
4 - 27	*51684790	PC Board Assy, MIXING VAR. RES.	
4 - 28	*51684800	PC Board Assy, MONITOR SWITCH	
4 - 29	*51684641	PC Board Assy, MIC AMPL.	
4 - 30	*55550271	Bracket, Mic Jack	
4 - 31	*51684840	PC Board Assy, TRIM VAR. RES.	
4 - 32	*51221020	Connector, Socket; 4P	
4 - 33	*51240260	Jack, PHONES	
4 - 34	*55531630	Bracket, Meter	
4 - 35	*51684652	PC Board Assy, REC SWITCH	
4 - 36	*55521940	Chassis, Ampl.	
4 - 37	*51221080	Connector Housing, Socket; 10P	
4 - 38	*55550280	Bracket, Jack	
4 - 39	*51650460	Meter, VU	
4 - 40	*50939110	Band, Meter	
4 - 41	*55330970	Escutcheon, Meter	
4 - 42	*51221090	Connector Housing, Socket; 11P	
4 - 43	*55521870	Panel, Ampl.; A	
4 - 44	*55344130	Knob, Output	
4 - 45	*50253820	Knob, B-30	
4 - 46	*60060040	Knob, B-15	
4 - 47	*55344880	Retainer, Cord; H	
4 - 48	*51221100	Connector Housing, Socket; 12P	
4 - 49	*55554810	Bracket, Control PC Board	
4 - 50	*55241130	Spring, Pressure	
4 - 51	*55551980	Spacer, Switch	

EXPLODED VIEW-5

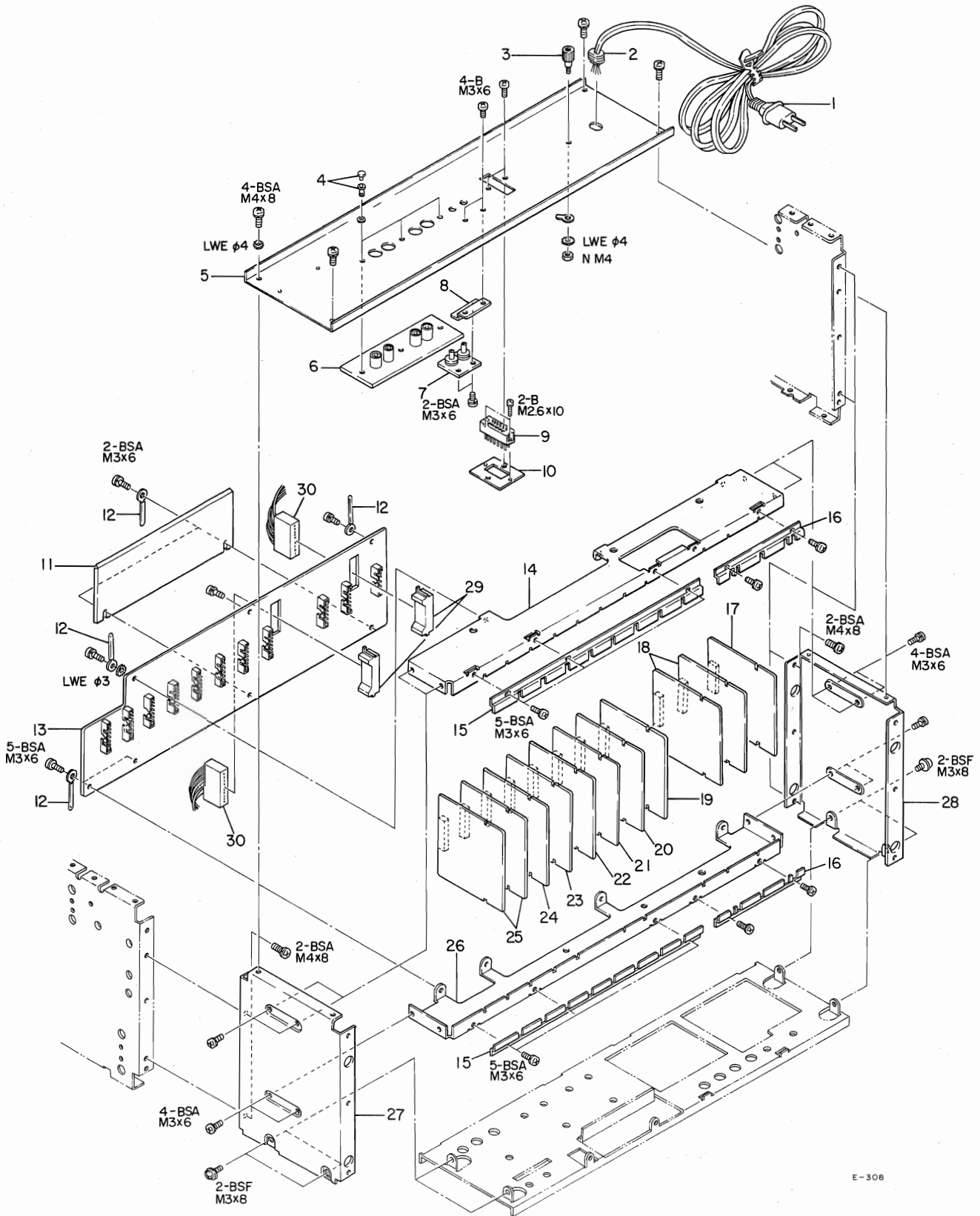

E-308

REF. NO.	PARTS NO.	DESCRIPTION	REMARKS
5 - 1	*51280270	Cord, AC Power	GENERAL EXPORT U.S.A., CANADA
	*50471661	Cord, AC Power	
5 - 2	*55300470	Strain Relief, AC Power Cord	
5 - 3	*50454071	Post, Grounding	
5 - 4	*55341180	Push Rivet	
5 - 5	*55521951	Panel, Rear Connection; A	
5 - 6	*51240350	Jack, Pin; 4P	
5 - 7	*51684670	PC Board Assy, METER CAL	
5 - 8	*55549940	Bracket, PC Board	
5 - 9	*50438411	Connector, Socket; 12P	
5 - 10	*55550340	Bracket, Connector; B	
5 - 11	*55551810	Shield Paper, REC	
5 - 12	*55810380	Retainer, Cord; A	
5 - 13	*51685650	PC Board Assy, MOTHER B	
5 - 14	*55521900	Holder, PC Board; R	
5 - 15	*55531560	Retainer, PC Board; A	
5 - 16	*55550040	Retainer, PC Board; B	
5 - 17	*51684961	PC Board Assy, BIAS OSC	
5 - 18	*51684984	PC Board Assy, REC EQ	
5 - 19	*51684880	PC Board Assy, PEAK INDICATOR	
5 - 20	*51684940	PC Board Assy, METER AMPL.	
5 - 21	*51684870	PC Board Assy, PHONE AMPL.	
5 - 22	*51684921	PC Board Assy, MUTING	
5 - 23	*51684911	PC Board Assy, PLAYBACK LINE	
5 - 24	*51684891	PC Board Assy, MIXER	
5 - 25	*51684972	PC Board Assy, PLAYBACK EQ	
5 - 26	*55521890	Holder, PC Board	
5 - 27	*55531660	Frame, Ampl.; R	
5 - 28	*55531650	Frame, Ampl.; L	
5 - 29	*51221240	Connector, Plug; 12P	
5 - 30	*51221100	Connector, Socket; 12P	

(Continued from page 7)

REF. NO.	PARTS NO.	DESCRIPTION	REMARKS
3 - 61	51630250	Solenoid	
3 - 62	*55550060	Bracket, Solenoid	
3 - 63	55810380	Retainer, Cord; A	
3 - 64	50141821	Shaft, Roller Arm	
3 - 65	55552920	Sheet, Roller; B	

2. TRANSISTOR SUBSTITUTION CHART

TYPE	PARTS NO.	REPLACEMENT	PARTS NO.
2SC1327(T)	50424610	2SC1222(E)	50424950
2SA666I(S)	50424210	2SA750(E)	51450380
		2SA733(P)	50425530
2SC1636-1	50425490	2SC1636-2	51450860
2SC945(P)	50425210	2SC536(G)	50424860
2SC1000(BL)	50424340	2SC1222(E)	50424950
2SA934-Q	51450840	2SA934-R	51450850
2SC945L(K)	51450360	2SC536(G)	50424860
2SC2060(Q)	51450820	2SC2060(R)	51450830

3. PC BOARD SECTION (Diagrams)

3-1. PLAYBACK EQ PC BOARD ASSY

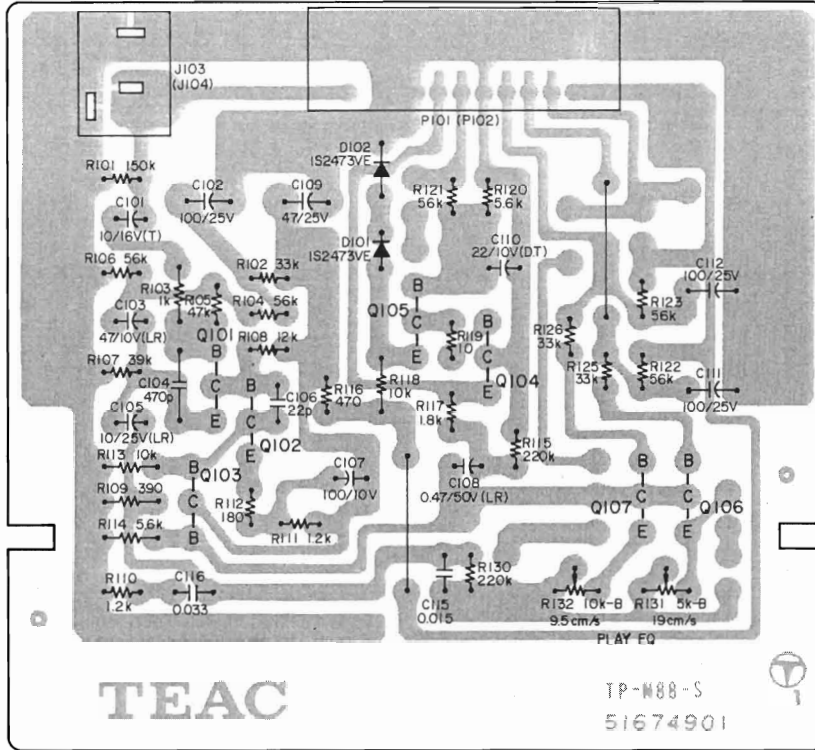

P-396

3-2. PLAYBACK LINE PC BOARD ASSY

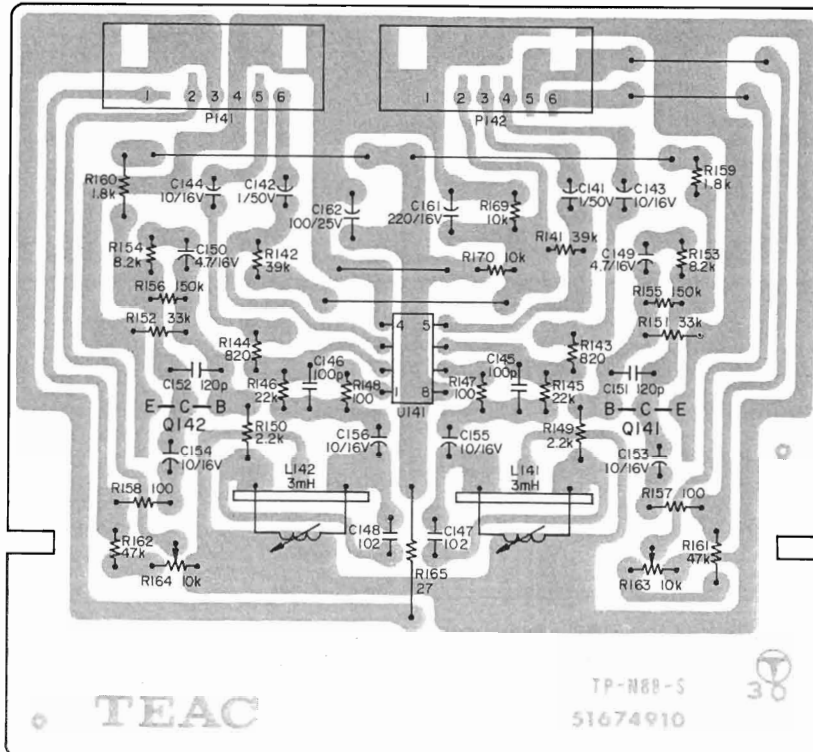

P-325-1

3-3. MUTING PC BOARD ASSY

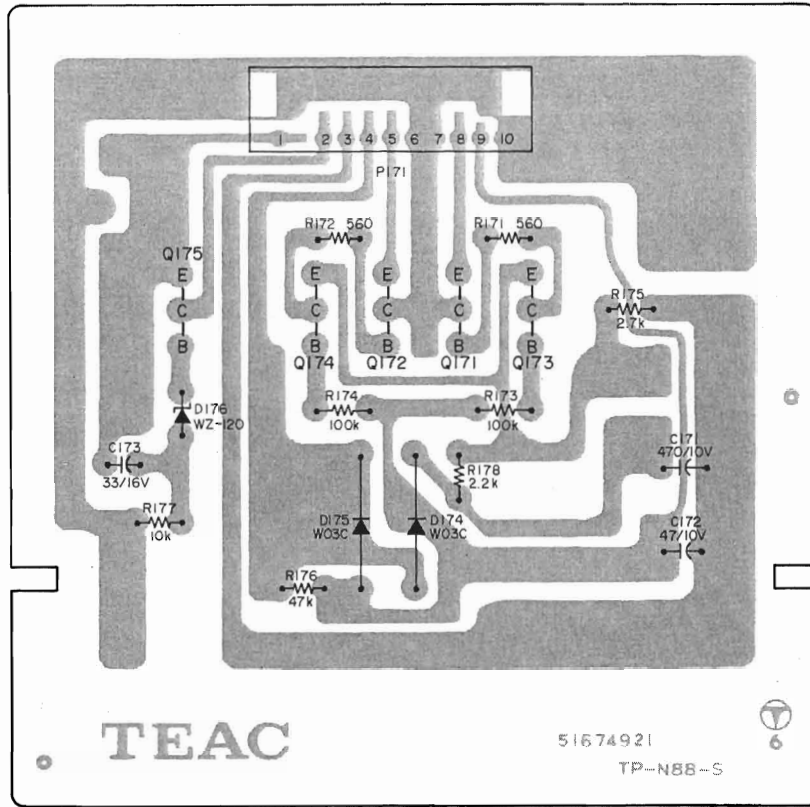

P-326

3-4. PHONE AMPL. PC BOARD ASSY

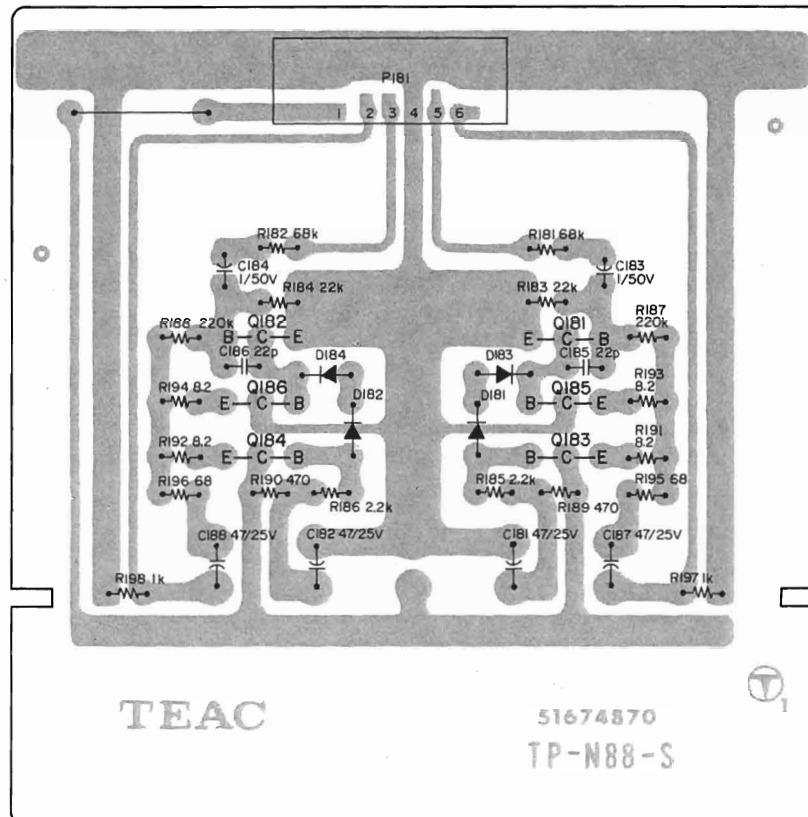

P-327

3-5. METER AMPL. PC BOARD ASSY

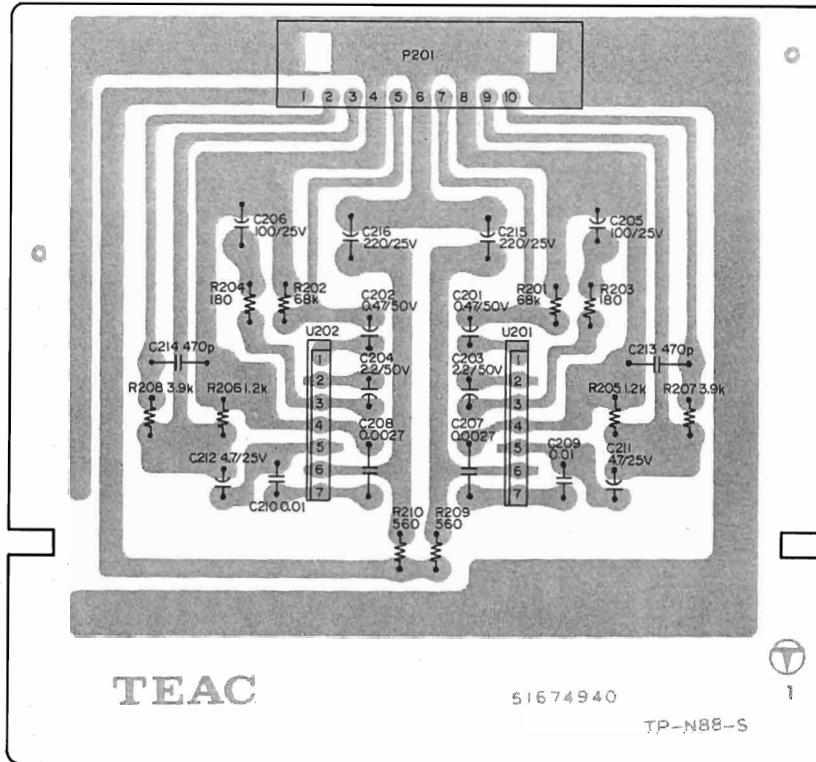

P-328

3-6. PEAK INDICATOR PC BOARD ASSY

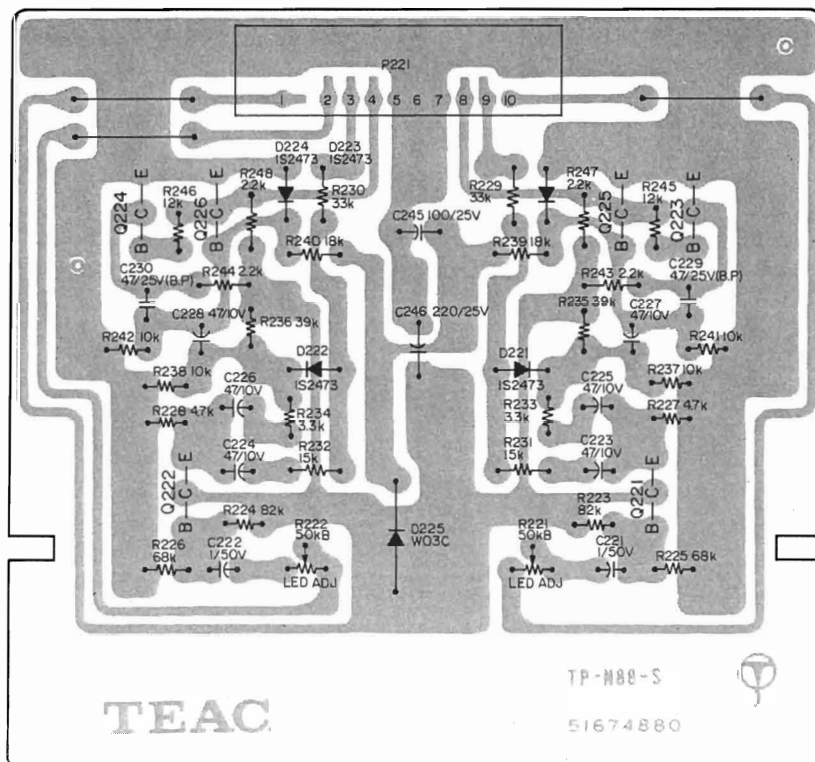

P-329

3-7. MIXER PC BOARD ASSY

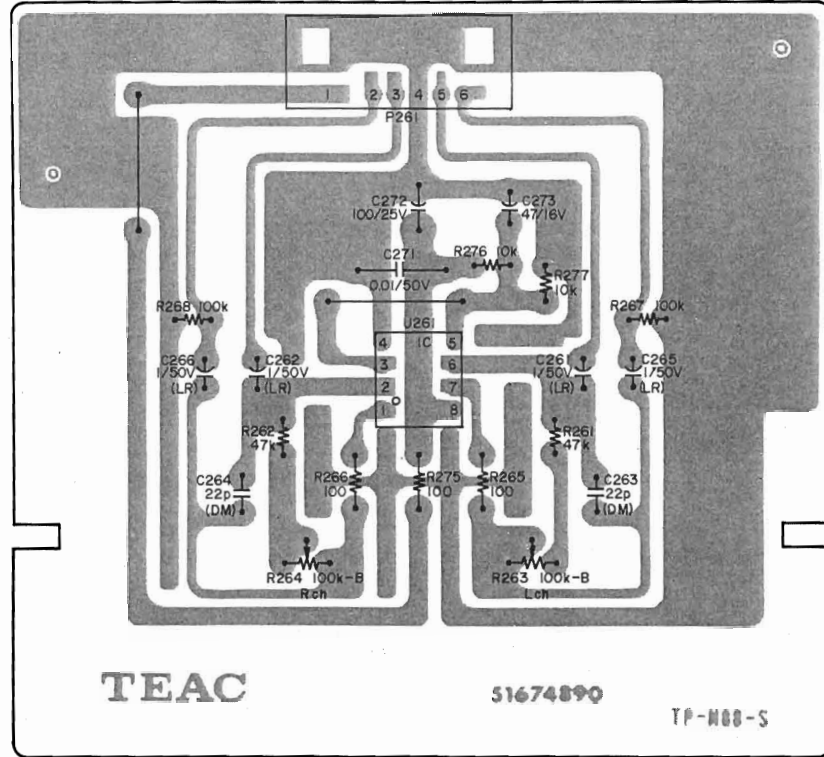

P-330

3-8. REC EQ PC BOARD ASSY

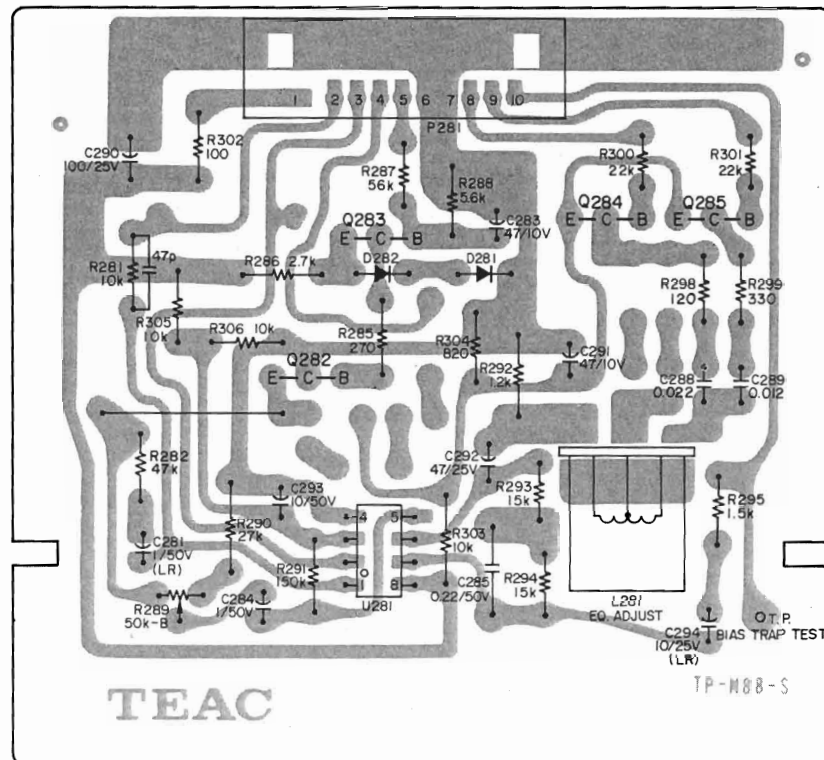

P-397

3-9. BIAS OSCILLATOR PC BOARD ASSY

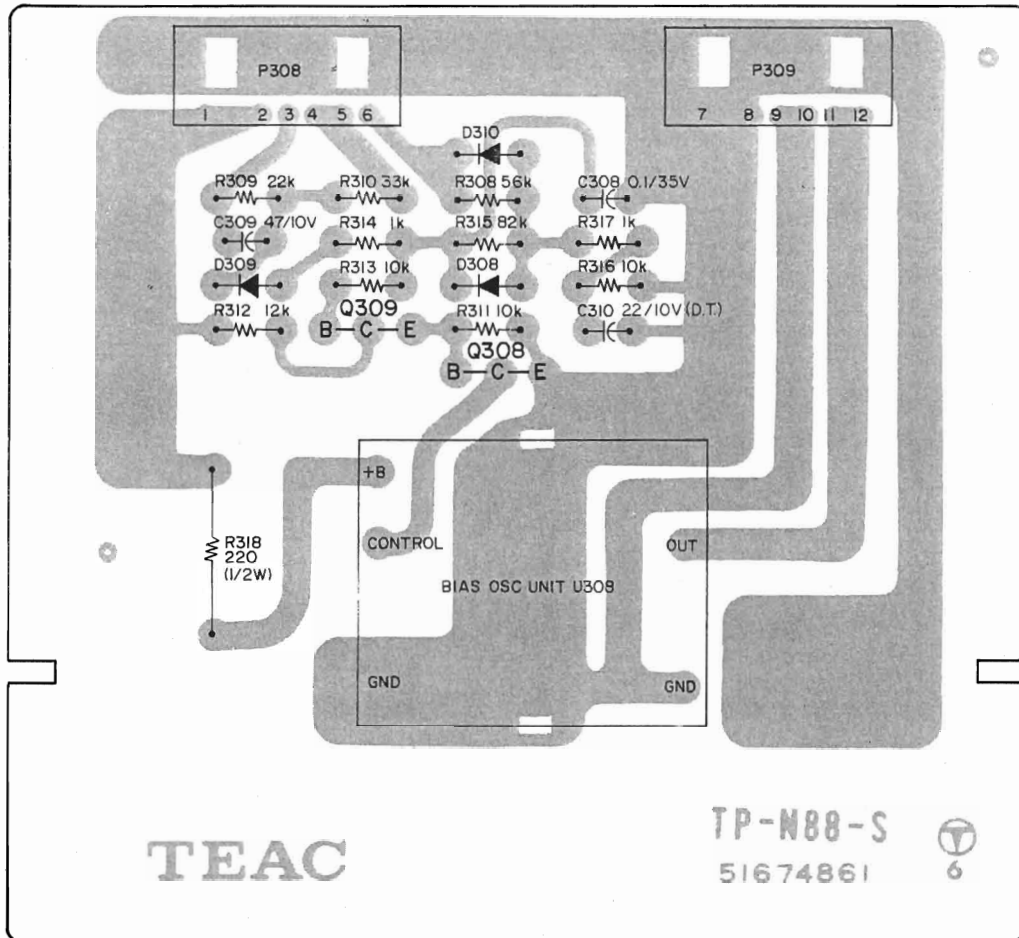

P-332-1

3-10. MIC AMPL. PC BOARD ASSY

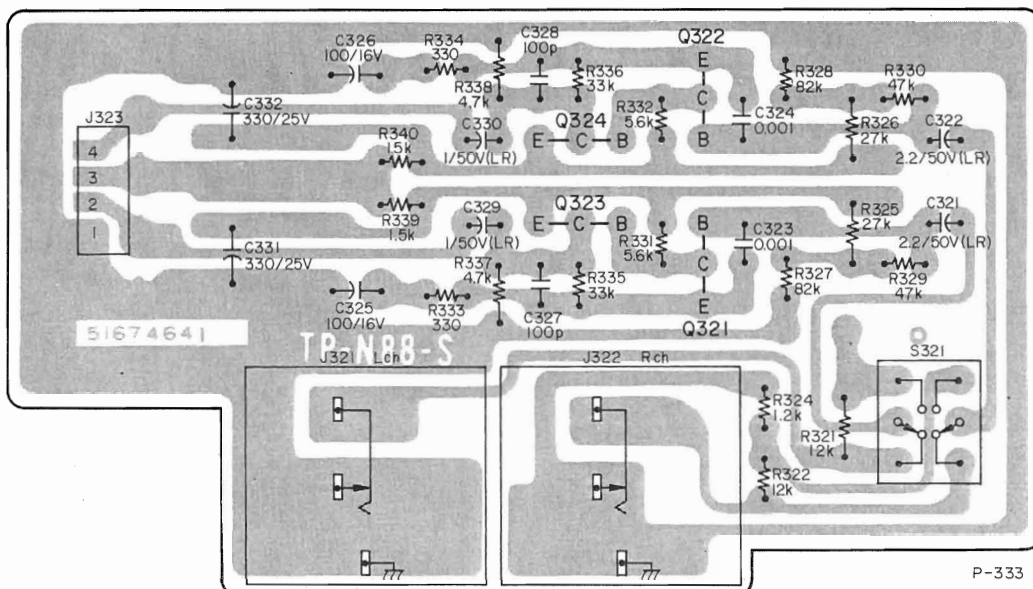

P-333

3-11. MIXING VAR. RES. PC BOARD ASSY

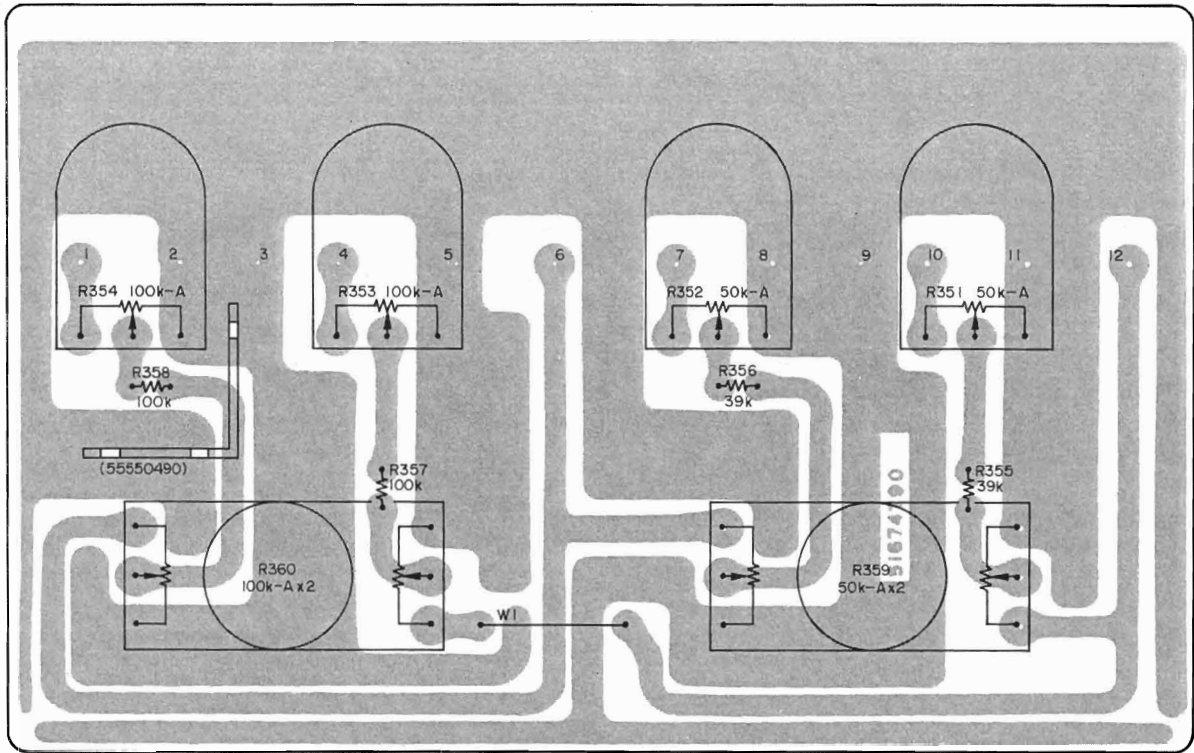

P-334

3-12. MONITOR SWITCH PC BOARD ASSY

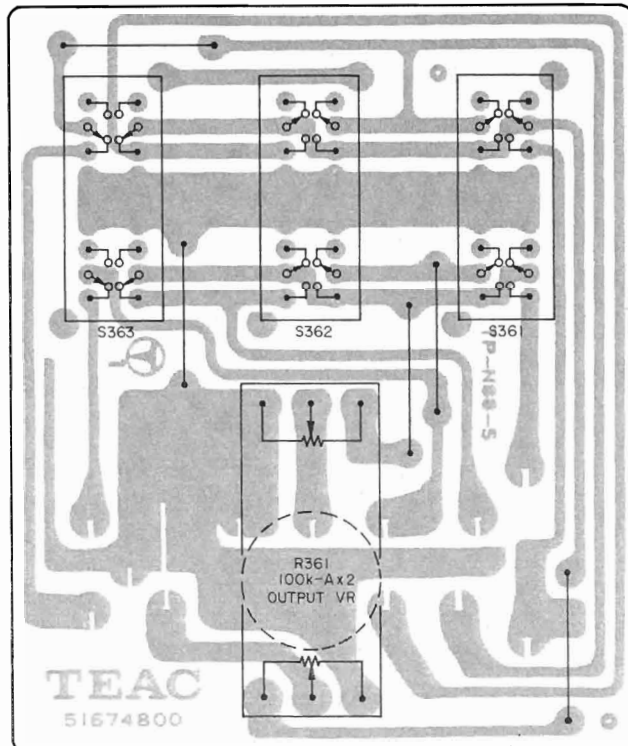

P-335

3-13. REC SWITCH PC BOARD ASSY

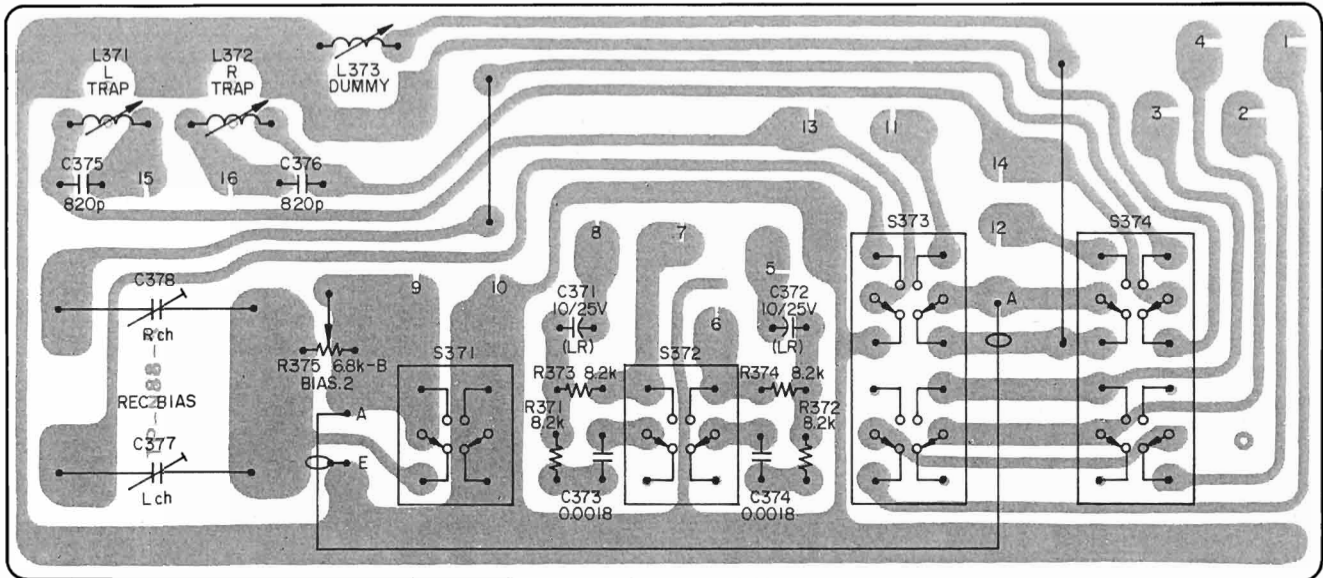

P-337

3-14. TRIM VAR. RES. PC BOARD ASSY

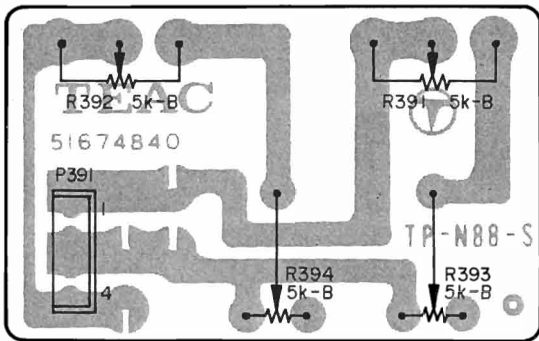

P-338

3-15. METER CAL PC BOARD

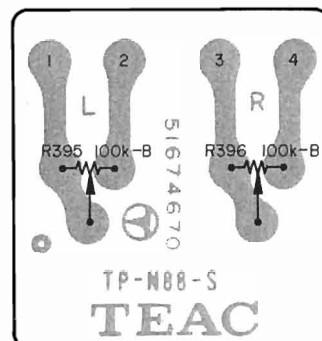

P-339

3-16. MOTHER PC BOARD ASSY

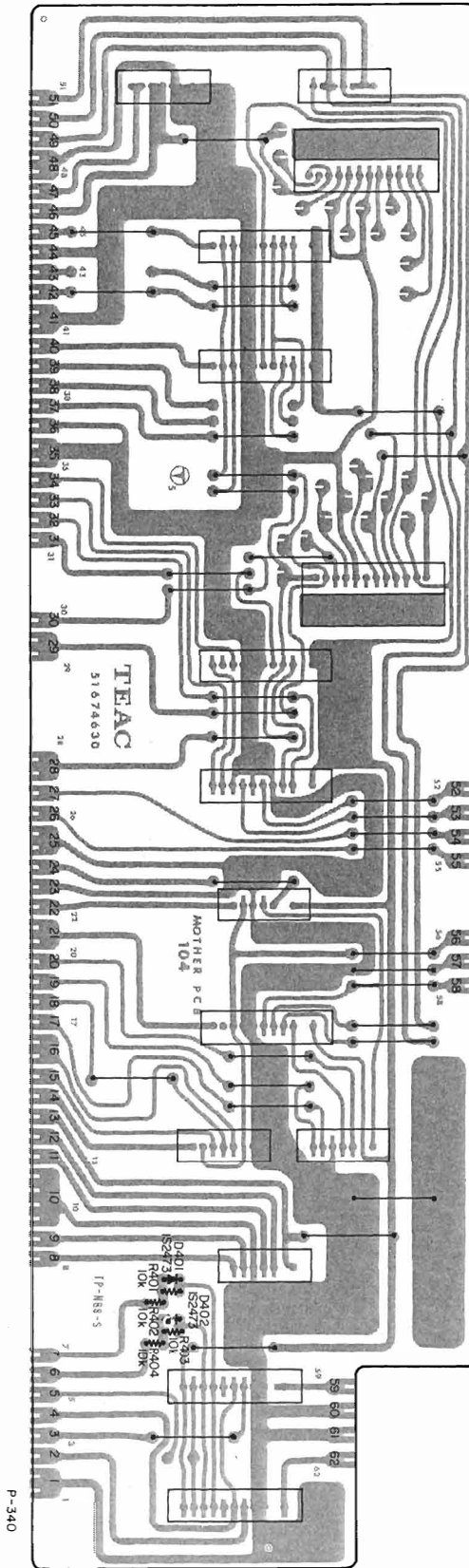

3-18. POWER SUPPLY PC BOARD ASSY

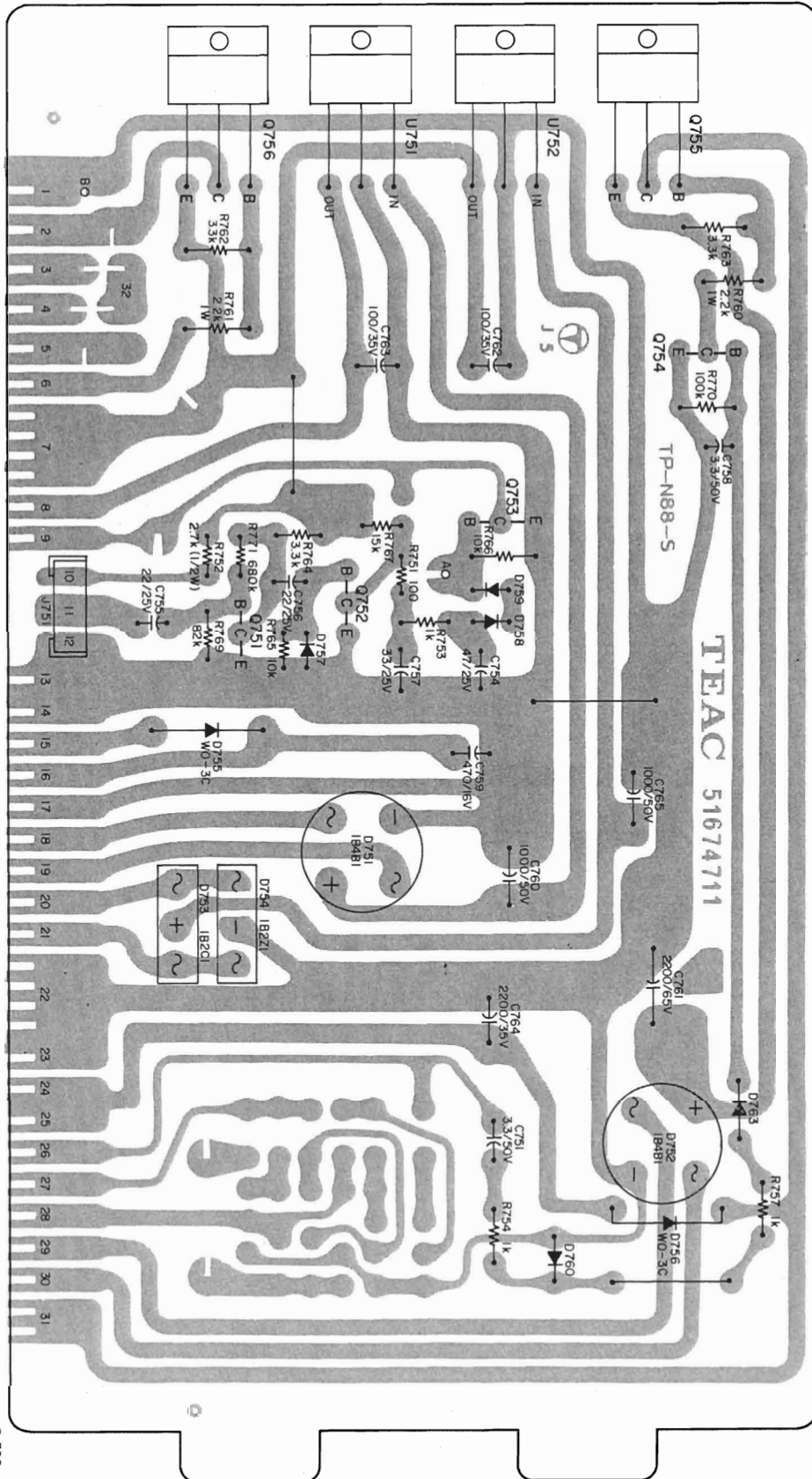

P-398

3-19. MOTOR RELAY PC BOARD ASSY

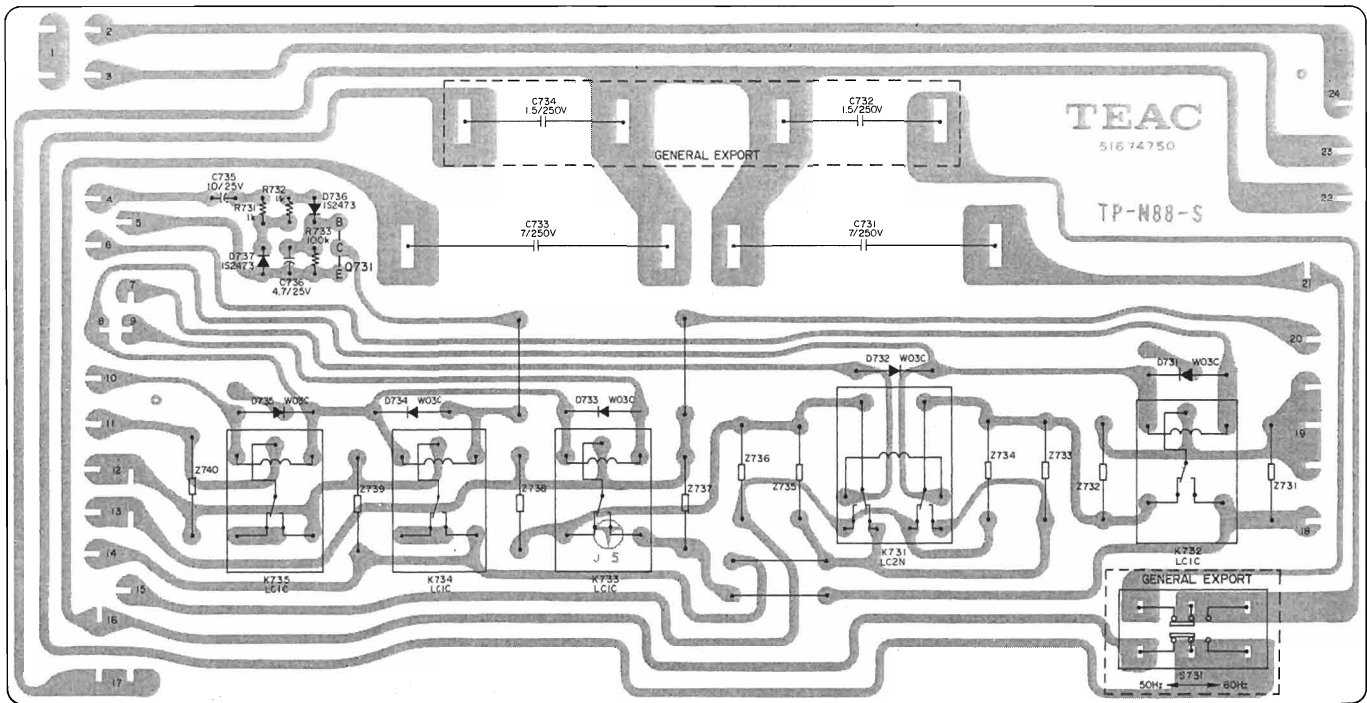

P-345-1

3-20. TENSION SERVO SENSOR PC BOARD ASSY

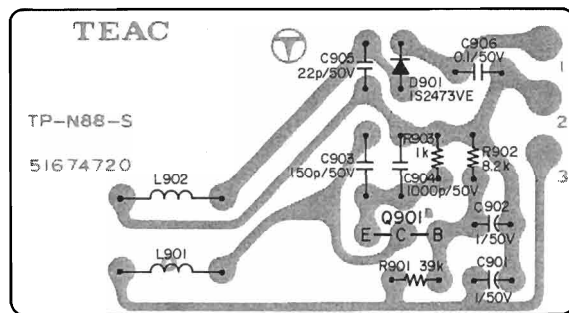

P-347

3. PC BOARD SECTION (Parts List)

3-1. PLAYBACK EQ PC BOARD ASSY

REF. NO.	PARTS NO.	DESCRIPTION
	51684972	PC Board Assy
	51674901	PC Board
TRANSISTORS		
Q101	50424610	2SC1327 (T)
Q102	50424210	2SA666I (S)
Q103, Q104	50423830	2SC536 (F)
Q105	50424210	2SA666I (S) or
	51450380	2SA750 (E)
Q106, Q107	50423870	2SC693 (G)
DIODES		
D101, D102	50425170	1S2473VE

CARBON RESISTORS

All resistors are rated $\pm 5\%$ tolerance and 1/4 watt.

R101	50571340	150k ohm
R102	50571180	33k ohm
R103	50570820	1k ohm
R104	50571240	56k ohm
R105	50571220	47k ohm
R106	50571240	56k ohm
R107	50571200	39k ohm
R108	50571080	12k ohm
R109	50570720	390 ohm
R110, R111	50570840	1.2k ohm
R112	50570640	180 ohm
R113	50571060	10k ohm
R114	50571000	5.6k ohm
R115	50571380	220k ohm
R116	50570740	470 ohm
R117	50570880	1.8k ohm
R118	50573060	10k ohm
R119	50570340	10 ohm
R120	50571000	5.6k ohm
R121	50571240	56k ohm
R122, R123	50571240	56k ohm
R125, R126	50571180	33k ohm
R130	50571380	220k ohm

CAPACITORS

C101	51700090	Tant.	10 mfd	16V
C102	50554170	Elec.	100 mfd	10V
C103	51700940	Elec.	47 mfd	10V (LR)
C104	50547560	Dip. Mica	470 pfd	50V
C105	51700820	Elec.	10 mfd	25V (LR)
C106	50543820	Dip. Mica	22 pfd	50V
C107	50554570	Elec.	100 mfd	10V
C108	51700850	Elec.	0.47 mfd	50V (LR)
C109	50554490	Elec.	47 mfd	25V
C110	50546501	Dip. Tant.	22 mfd	10V
C111, C112	50554170	Elec.	100 mfd	25V
C115	50548870	Mylar	0.015 mfd	50V 5%
C116	50549000	Mylar	0.033 mfd	50V 5%

REF. NO.	PARTS NO.	DESCRIPTION
VARIABLE RESISTORS		
R131	51501530	Semi-fixed, 5k ohm - B
R132	51501540	Semi-fixed, 10k ohm - B
MISCELLANEOUS		
P101	50438450	Connector, Socket 10P
J103	51240320	Pin Jack
	51812070	Jumper x 2

3-2. PLAYBACK LINE PC BOARD ASSY

REF. NO.	PARTS NO.	DESCRIPTION
	51684911	PC Board Assy
	51674910	PC Board
IC		
U141	51470240	NJM4558D-F
TRANSISTORS		
Q141, Q142	50423830	2SC536 (F)
RESISTORS		
All resistors are rated $\pm 5\%$ tolerance, 1/4 watt and of carbon type unless otherwise noted.		
R141/R142	50571200	39k ohm
R143/R144	50570800	820 ohm
R145/R146	50571140	22k ohm
R147/R148	50570580	100 ohm
R149/R150	50570900	2.2k ohm
R151/R152	50571180	33k ohm
R153/R154	50571040	8.2k ohm
R155/R156	50571340	150k ohm
R157/R158	50570580	100 ohm
R159/R160	50570880	1.8k ohm
R161/R162	50571220	47k ohm
R165	51818340	Non-Flamable 27 ohm
R169/R170	50571060	10k ohm

CAPACITORS

C141/C142	50554540	Elec.	1 mfd	50V
C143/C144	50554050	Elec.	10 mfd	16V
C145/C146	50547440	Dip. Mica	100 pfd	50V
C147/C148	50548780	Mylar	0.001 mfd	50V 5%
C149/C150	50554430	Elec.	4.7 mfd	16V
C151/C152	50542560	Dip. Mica	120 pfd	50V
C153/C154	50554050	Elec.	10 mfd	16V
C155/C156	50554050	Elec.	10 mfd	16V
C161	50554390	Elec.	220 mfd	16V
C162	50554170	Elec.	100 mfd	25V
C163	50542040	Ceramic	0.01 mfd	50V

REF. NO.	PARTS NO.	DESCRIPTION
VARIABLE RESISTORS		
R163/R164	51501540	Semi-fixed, 10k ohm - B
COILS		
L141/L142	50566590	Trap, 3 mH
MISCELLANEOUS		
P141/P142	50438460	Connector, Socket 6P
	51670120	PC Board, Coil
	51812070	Jumper, JPW-02-F8 x 1
	51812060	Jumper, JPW-02-F5 x 1
	51812090	Jumper, JPW-02 x 3

3-3. MUTING PC BOARD ASSY

REF. NO.	PARTS NO.	DESCRIPTION
	51684921	PC Board Assy
	51674921	PC Board
Q171/Q172	50425490	Transistor, 2SC1636-I
Q173/Q174	50424210	Transistor, 2SA666I (S)
Q175	51450450	Transistor, 2SA719-Q
D174, D175	51430890	Diode, W03C
D176	50422810	Zener Diode, WZ-120
R171/R172	50570760	Carbon Res., 560 ohm 1/4W 5%
R173/R174	50571300	Carbon Res., 100k ohm 1/4W 5%
R175	50570920	Carbon Res., 2.7k ohm 1/4W 5%
R176	50571220	Carbon Res., 47k ohm 1/4W 5%
R177	50571060	Carbon Res., 10k ohm 1/4W 5%
R178	50570900	Carbon Res., 2.2k ohm 1/4W 5%
C171	50555380	Elec. Cap. 470 mfd 10V
C172	50555540	Elec. Cap. 47 mfd 10V
C173	50554260	Elec. Cap. 33 mfd 16V
P171	50438450	Connector, Socket 10P

3-4. PHONE AMPL. PC BOARD ASSY

REF. NO.	PARTS NO.	DESCRIPTION
	51684870	PC Board Assy
	51674870	PC Board
TRANSISTORS		
Q181/Q182	50425210	2SC945 (P)
Q183/Q184	51450460	2SC1317 (Q)
Q185/Q186	51450450	2SA719 (Q)

REF. NO.	PARTS NO.	DESCRIPTION
DIODES		
D181/D182	50425170	1S2473 VE
D183/D184	50425170	1S2473 VE

CARBON RESISTORS All resistors are rated $\pm 5\%$ tolerance and 1/4 watt

R181/R182	50571260	68k ohm
R183/R184	50571140	22k ohm
R185/R186	50570900	2.2k ohm
R187/R188	50571380	220k ohm
R189/R190	50570740	470 ohm
R191/R192	50570320	8.2 ohm
R193/R194	50570320	8.2 ohm
R195/R196	50570540	68 ohm
R197/R198	50570820	1k ohm

CPACITORS

C181/C182	50554490	Elec.	47 mfd	25V
C183/C184	50554540	Elec.	1 mfd	50V
C185/C186	50543820	Dip. Mica	22 pfd	50V
C187/C188	50554490	Elec.	47 mfd	25V

MISCELLANEOUS

P181	50438460	Connector, Socket 6P
	51812090	Jumper, JPW-02 x 1

3-5. METER AMPL. PC BOARD ASSY

REF. NO.	PARTS NO.	DESCRIPTION
	51684940	PC Board Assy
	51674940	PC Board
IC's		
U201/U202	50427370	TA-7140P

CARBON RESISTORS All resistors are rated $\pm 5\%$ tolerance and 1/4 watt

R201/R202	50571260	68k ohm
R203/R204	50570640	180 ohm
R205/R206	50570840	1.2k ohm
R207/R208	50570960	3.9k ohm
R209/R210	50570560	560 ohm

CAPACITORS

C201/C202	50554970	Elec.	0.47 mfd	50V
C203/C204	50554980	Elec.	2.2 mfd	50V
C205/C206	50554170	Elec.	100 mfd	25V
C207/C208	50548590	Mylar	0.0027 mfd	50V
C209/C210	50548020	Mylar	0.01 mfd	50V

REF. NO.	PARTS NO.	DESCRIPTION
C211/C212	50554530	Elec. 4.7 mfd 25V
C213/C214	50547560	Dip. Mica 470 pfd 50V
C215/C216	50554180	Elec. 220 mfd 25V

MISCELLANEOUS

P201	50438450	Connector, Socket 10P
------	----------	-----------------------

3-6. PEAK INDICATOR PC BOARD ASSY

REF. NO.	PARTS NO.	DESCRIPTION
	51684880	PC Board Assy
	51674880	PC Board
TRANSISTORS		
Q221/Q222	50424860	2SC536 (G)
Q223/Q224	50424860	2SC536 (G)
Q225/Q226	50424860	2SC536 (G)

DIODES

D221/D222	50425170	1S2473VE
D223/D224	50425170	1S2473VE
D225	51430890	W03C

CARBON RESISTORS

All resistors are rated $\pm 5\%$ tolerance and 1/4 watt.

R223/R224	50571280	82k ohm
R225/R226	50571260	68k ohm
R227/R228	50570980	4.7k ohm
R229/R230	50571180	33k ohm
R231/R232	50571100	15k ohm
R233/R234	50570940	3.3k ohm
R235/R236	50571200	39k ohm
R237/R238	50571060	10k ohm
R239/R240	50571120	18k ohm
R241/R242	50571060	10k ohm
R243/R244	50570900	2.2k ohm
R245/R246	50571080	12k ohm
R247/R248	50570900	2.2k ohm

CAPACITORS

C221/C222	50554540	Elec. 1 mfd 50V
C223/C224	50555540	Elec. 47 mfd 10V
C225/C226	50555540	Elec. 47 mfd 10V
C227/C228	50555540	Elec. 47 mfd 10V
C229/C230	50559090	Elec. 4.7 mfd 25V (Bi-polar)
C245	50554170	Elec. 100 mfd 25V
C246	50554180	Elec. 220 mfd 25V

VARIABLE RESISTORS

R221/R222	51501560	Semi-fixed, 50k ohm - B
-----------	----------	-------------------------

REF. NO.	PARTS NO.	DESCRIPTION
MISCELLANEOUS		
P221	50438450	Connector, Socket 10P
	51812070	Jumper, JPW-02-FB x 1
	51812090	Jumper, JPW-02 x 3

3-7. MIXER PC BOARD ASSY

REF. NO.	PARTS NO.	DESCRIPTION
	51684891	PC Board Assy
	51674890	PC Board
U261	51470240	IC, NJM4558D-F
R261/R262	50571220	Carbon Res., 47k ohm 1/4W 5%
R265/R266	50570580	Carbon Res., 100 ohm 1/4W 5%
R267/R268	50571000	Carbon Res., 100k ohm 1/4W 5%
R275	51818480	Non-Flamabl Res., 100 ohm 1/4W 5%
R276, R277	50571060	Carbon Res., 10k ohm 1/4W 5%
C261/C262	51700860	Elec. Cap., 1 mfd 50V (LR)
C263/C264	50543820	Dip. Mica Cap., 22 pfd 50V
C265/C266	51700860	Elec. Cap. 1 mfd 50V (LR)
C271	50542040	Ceramic Cap., 0.01 mfd 50V
C272	50554170	Elec. Cap 100 mfd 25V
C273	50554010	Elec. Cap. 47 mfd 16V
R263/R264	51501570	Var. Res., Semi-fixed 100k ohm-B
P261	50438460	Connector, Socket 6P
	51812070	Jumper, JPW-02-F8

3-8. REC EQ PC BOARD ASSY

REF. NO.	PARTS NO.	DESCRIPTION
	51684984	PC Board Assy
	51674931	PC Board
IC		
U281	51470240	NJM4558D-F
TRANSISTORS		
Q282	50423830	2SC536 (F)
Q283	50424210	2SA6661 (S)
Q284, Q285	50423830	2SC536 (F)
DIODES		
D281, D282	50425170	1S2473VE

3-9. BIAS OSCILLATOR PC BOARD ASSY

REF. NO.	PART NO.	DESCRIPTION
----------	----------	-------------

RESISTORS

All resistors are rated $\pm 5\%$ tolerance, 1/4 watt and of carbon type unless otherwise noted.

R281	50571060	10k ohm
R282	50571220	47k ohm
R285	50570680	270 ohm
R286	50570920	2.7k ohm
R287	50571240	56k ohm
R288	50571000	5.6k ohm
R290	50571160	27k ohm
R291	50571340	150k ohm
R292	50570840	1.2k ohm
R293	50571100	15k ohm
R294	50571100	15k ohm
R295	50570860	1.5k ohm
R298	50570600	120 ohm
R299	50570700	330 ohm
R300, R301	50571140	22k ohm
R302	51818480	Non-Flamable 100 ohm
R303	50571060	10k ohm
R304	50570800	820 ohm
R305, R306	50571060	10k ohm

CAPACITORS

C281	51700860	Elec.	1 mfd	50V (LR)
C283	50555540	Elec.	47 mfd	10V
C284	51700860	Elec.	1 mfd	50V (LR)
C285	50549320	Mylar	0.22 mfd	50V 5%
C288	50548980	Mylar	0.022 mfd	50V 5%
C289	50548950	Mylar	0.012 mfd	50V 5%
C290	50554170	Elec.	100 mfd	25V
C291	50555540	Elec.	47 mfd	10V
C292	50554490	Elec.	47 mfd	25V
C293	50554350	Elec.	10 mfd	50V
C294	51700820	Elec.	10 mfd	25V (LR)

VARIABLE RESISTOR

R289	51501560	Semi-fixed, 50k ohm - B
------	----------	-------------------------

COIL

L281	50566670	Record EQ
------	----------	-----------

MISCELLANEOUS

P281	51674830	PC Board Record EQ Coil
	50438450	Connector, Socket 10P
	57240420	Pin, F3-type x 1
	51812060	Jumper, JPW-02-F5 x 1
	51812070	Jumper, JPW-02-F8 x 1

REF. NO.	PARTS NO.	DESCRIPTION
----------	-----------	-------------

51684962 PC Board Assy

51674861 PC Board

TRANSISTORS

Q308	50424670	2SC1317 - R
Q309	50423830	2SC536 (F)

DIODES

D308~D310	50425170	1S2473VE
-----------	----------	----------

CARBON RESISTORS

All resistors are rated $\pm 5\%$ tolerance and 1/4 watt unless otherwise noted.

R308	50571240	56k ohm
R309	50571140	22k ohm
R310	50571180	33k ohm
R311	50571060	10k ohm
R312	50571080	12k ohm
R313	50571060	10k ohm
R314	50570820	1k ohm
R315	50571280	82k ohm
R316	50571060	10k ohm
R317	50570820	1k ohm
R318	50574660	220 ohm 1/2W

CAPACITORS

C308	50546641	Dip. Tant.	0.1 mfd	35V
C309	50555540	Elec.	47 mfd	10V
C310	50546501	Dip. Tant.	22 mfd	10V

MISCELLANEOUS

U308	50400900	OSC Unit
P308, P309	50438460	Connector, Socket 6P

3-10. MIC AMPL. PC BOARD ASSY

REF. NO.	PARTS NO.	DISCRIPTION
----------	-----------	-------------

51684641 PC Board Assy

51674641 PC Board

TRANSISTORS

Q321/Q322	50424340	2SC1000 (BL)
Q323/Q324	50424210	2SA666 I S

CARBON RESISTORS

All resistors are rated $\pm 5\%$ tolerance and 1/4 watt

R321/R322	50571080	12k ohm
R323/R324	50570840	1.2k ohm
R325/R326	50571160	27k ohm
R327/R328	50571280	82k ohm

3-13. REC SWITCH PC BOARD ASSY

REF. NO.	PART NO.	DESCRIPTION
R329/R330	50571220	47k ohm
R331/R332	50571000	5.6k ohm
R333/R334	50570700	330 ohm
R335/R336	50571180	33k ohm
R337/R338	50570980	4.7k ohm
R339/R340	50570860	1.5k ohm

CAPACITORS

C321/C322	51700870	Elec.	2.2 mfd	50V
C323/C324	50548320	Mylar	0.001 mfd	50V
C325/C326	50554200	Elec.	100 mfd	16V
C327/C328	50547440	Dip. Mica	100 pfd	50V
C329/C330	51700860	Elec.	1 mfd	50V
C331/C332	50554960	Elec.	330 mfd	25V

MISCELLANEOUS

J321/J322	51240450	Jack, MIC
J323	51221140	Connector, Plug 4P
S321	51340300	Switch, Push DPDT

3-11. MIXING VAR. RES. PC BOARD ASSY

REF. NO.	PARTS NO.	DESCRIPTION
	51684790	PC Board Assy
	51674790	PC Board
R351, R352	51501930	Var. Res. 50k ohm - A
R353, R354	51501910	Var. Res. 100k ohm - A
R359	51501950	Var. Res. 50k ohm - A x 2
R560	51501920	Var. Res. 100k ohm - A x 2
R355, R356	50571200	Carbon, Res. 39k ohm 1/4W 5%
R357, R358	50571300	Carbon, Res. 100k ohm 1/4W 5%
	51812070	Jumper, JPW-02-F8 x 1
	55550490	Cover, Shield x 1

3-12. MONITOR SWITCH PC BOARD ASSY

REF. NO.	PARTS NO.	DESCRIPTION
	51684800	PC Board Assy
	51674800	PC Board
R361	51561920	Var. Res. 100k ohm - A x 2
S361~S363	51340310	Push Switch, 3-gang
	51812070	Jumper, JPW-02-F8 x 5

REF. NO.	PARTS NO.	DESCRIPTION
	51684652	PC Board Assy
	51674651	PC Board
R371/R372	50571040	Carbon Res., 8.2k ohm 1/4W 5%
R373/R374	50571040	Carbon Res., 8.2k ohm 1/4W 5%
R375	50539220	Semi-fixed Var. Res., 6.8k ohm - B
C371/C372	51700820	Elec. Cap., 10 mfd 25V (LR)
C373/C374	50548880	Mylar Cap., 0.0018 mfd 50V 5%
C375/C376	50543440	Polyst. Cap., 820pfd 50V
C377/C378	51700290	Trimmer Cap., Max. 70 pfd
L371/L372	50566590	Trap Coil, 3 mH
L373	50566581	Dummy Coil, 3 mH
S371~S374	51340280	Push Switch, 4-gang
	51812070	Jumper, JPW-02-F8 x 2

3-14. TRIM VAR. RES. PC BOARD ASSY

REF. NO.	PARTS NO.	DESCRIPTION
	51684840	PC Board Assy
	51674840	PC Board
P391	51221140	Connector, Plug; 4P
R391, R392	51501970	Var. Res. 5k ohm - B
R393, R394	51500970	Var. Res., Semi-fixed 5k ohm - B

3-15. METER CAL PC BOARD ASSY

REF. NO.	PARTS NO.	DESCRIPTION
	51684670	PC Board Assy
	51674670	PC Board
R395, R396	50533490	Var. Res. 100k ohm - B

3-16. MOTHER PC BOARD ASSY

REF. NO.	PARTS NO.	DESCRIPTION
	51685650	PC Board Assy, B
	51674630	PC Board
D401/D402	50425170	Diode, 1S2473VE
R401/R402	50571060	Carbon Res., 10k ohm 1/4W 5%
R403/R404	50571060	Carbon Res., 10k ohm 1/4W 5%
J101, J102	51220120	Connector, Plug 10P
J171, J201	51220120	Connector, Plug 10P

REF. NO.	PART NO.	DESCRIPTION
J221	51220120	Connector, Plug 10P
J281, J282	51220120	Connector, Plug 10P
J141, J142	51220100	Connector, Plug 6P
J181, J261	51220100	Connector, Plug 6P
J301, J302	51220100	Connector, Plug 6P
J457, J458	51221240	Connector, Plug 12P
	51281206	Jumper, JPW-02-F5 x 34

3-17. CONTROL PC BOARD ASSY B

REF. NO.	PARTS NO.	DESCRIPTION
	51686200	PC Board Assy
	51674702	PC Board
TRANSISTORS		
Q511~Q534	51450360	2SC945LK
Q535	50424670	2SC1317 (R)
Q536~Q540	51450360	2SC945LK
Q541	50424670	2SC1317 (R)
Q542~Q549	51450360	2SC945LK
Q550, Q551	50424670	2SC1317 (R)
Q552~Q553	51450360	2SC945LK
Q556, Q557	51450360	2SC945LK
Q558, Q559	50424670	2SC1317 (R)
Q560~Q564	51450360	2SC945LK
Q565	50424670	2SC1317 (R)
Q566~Q576	50450360	2SC945LK
Q578~Q583	50450360	2SC945LK
Q584~Q587	51450770	2SD600K (E)
Q588	51450840	2SA934 (Q)
Q590	50425530	2SA744 (P)
Q591	51450360	2SC945LK

DIODES

D511~D569	50425170	1S2473VE
D570, D571	51430890	W03C
D572~D608	50425170	1S2473VE
D609	51430890	W03C
D610	50425140	Zener, WZ-061
D611	50425170	1S2473VE
D613~D622	50425140	Zener, WZ-061
D623	50425170	1S2473VE

CARBON RESISTORS

All resistors are rated $\pm 5\%$ tolerance, and
1/4 watt unless otherwise noted.

R511, R512	50571060	10k ohm
R513, R514	50571100	15k ohm
R517, R518	50571060	10k ohm
R519, R520	50571100	15k ohm
R523, R524	50571060	10k ohm
R525, R526	50571100	15k ohm
R529, R530	50571060	10k ohm
R531, R532	50571100	15k ohm

REF. NO.	PART NO.	DESCRIPTION
R535, R536	50571060	10k ohm
R537, R538	50571100	15k ohm
R541	50571240	56k ohm
R542	50571080	12k ohm
R543, R544	50571140	22k ohm
R546	50570820	1k ohm
R567	50571340	150k ohm
R548	50570900	2.2k ohm
R549	50571140	22k ohm
R550	50571060	10k ohm
R551	50571220	47k ohm
R552	50571140	22k ohm
R553~R557	50571060	10k ohm
R562	50571060	10k ohm
R563, R564	50571300	100k ohm
R565	50571060	10k ohm
R566, R567	50571300	100k ohm
R568	50571140	22k ohm
R569, R570	50571300	100k ohm
R571	50571140	22k ohm
R572	50571060	10k ohm
R573	50571140	22k ohm
R574, R575	50571060	10k ohm
R576	50571140	22k ohm
R577, R578	50571060	10k ohm
R579	50571140	22k ohm
R580, R581	50571060	10k ohm
R582	50571140	22k ohm
R583	50571060	10k ohm
R584	50571140	22k ohm
R585	50571060	10k ohm
R586, R587	50571140	22k ohm
R588, R589	50571060	10k ohm
R590	50571140	22k ohm
R591	50571060	10k ohm
R592	50571140	22k ohm
R593	50571060	10k ohm
R594	50571140	22k ohm
R595, R596	50571060	10k ohm
R597	50571140	22k ohm
R598	50571060	10k ohm
R599	50571140	22k ohm
R600	50571060	10k ohm
R601	50571140	22k ohm
R602	50571060	10k ohm
R603, R604	50571140	22k ohm
R605	50571060	10k ohm
R606	50571140	22k ohm
R607, R608	50571060	10k ohm
R609	50571140	22k ohm
R610, R611	50571060	10k ohm
R612, R613	50571140	22k ohm
R614	50570980	4.7k ohm
R615	50570740	470 ohm
R616	50570980	4.7k ohm
R617	50571040	8.2k ohm
R618	50570900	2.2k ohm
R619	50571140	22k ohm
R620, R621	50571060	10k ohm
R622	50571140	22k ohm
R623	50571060	10k ohm
R624	50571140	22k ohm
R625	50571060	10k ohm
R626	50571140	22k ohm

REF. NO.	PARTS NO.	DESCRIPTION
R627	50571060	10k ohm
R628	50571140	22k ohm
R629	50571060	10k ohm
R630	50571140	22k ohm
R631, R632	50571060	10k ohm
R633	50571140	22k ohm
R634, R635	50570940	3.3k ohm
R636	50570180	2.2k ohm
R637	50571140	22k ohm
R638	50571060	10k ohm
R639	50571140	22k ohm
R640, R631	50571280	82k ohm
R642	50571140	10k ohm
R643	50571160	27k ohm
R645	50571060	10k ohm
R646	50571140	22k ohm
R647	50571060	10k ohm
R648	50571140	22k ohm
R649	50571060	10k ohm
R650	50571140	22k ohm
R651	50570940	3.3k ohm
R652	50571060	10k ohm
R653	50571140	22k ohm
R654	50571060	10k ohm
R656, R657	50571060	10k ohm
R658~R660	50571140	22k ohm
R661	50571060	10k ohm
R662	50571140	22k ohm
R663	50571060	10k ohm
R664	50571140	22k ohm
R665, R666	50571220	47k ohm
R667	50571060	10k ohm
R668	50571240	56k ohm
R669	50571140	22k ohm
R670	50571300	100k ohm
R671	50571060	10k ohm
R672	50571140	22k ohm
R673	50571060	10k ohm
R674	50571140	22k ohm
R675	50571060	10k ohm
R676, R677	50571140	22k ohm
R678, R679	50571060	10k ohm
R680	50571140	22k ohm
R681, R682	50570820	1k ohm
R683, R684	50570860	1.5k ohm
R685, R686	50571140	22k ohm
R687	50571060	10k ohm
R688	51571060	10k ohm
R689	51570580	100 ohm
R690	51571060	10k ohm
R691~R694	51802860	1.5k ohm 1/2W
R695~R700	51571060	10k ohm
R701	50571060	10k ohm
R702~R705	51571060	10k ohm
R706	50571500	680k ohm
R707	50571060	10k ohm
R708, R709	51571060	10k ohm
R710	50571140	22k ohm
R713, R714	50571060	10k ohm
R715	50570980	100k ohm

REF. NO.	PART NO.	DESCRIPTION
CAPACITORS		
C511~C520	50548020	Mylar 0.01 mfd 50V 10%
C521	51700860	Elec. 1 mfd 50V (LR)
C522	50554630	Elec. 100 mfd 35V
C523~C528	50542040	Ceramic 0.01 mfd 50V
C530	50546681	Dip. Tant. 0.47 mfd 35V
C531	51700810	Elec. 4.7 mfd 25V (LR)
C532, C533	50548020	Mylar 0.01 mfd 50V 10%
C534	50554510	Elec. 10 mfd 35V
C535	50546681	Dip. Tant. 0.47 mfd 35V
C536	50548020	Mylar 0.01 mfd 50V 10%
C537	50549730	Elec. 47 mfd 25V (KU)
C538	50554750	Elec. 22 mfd 35V
C539, C540	51700810	Elec. 4.7 mfd 25V (LR)
C541, C543	50554170	Elec. 100 mfd 25V
C542	50554950	Elec. 22 mfd 25V
C544	50546701	Dip. Tant. 1 mfd 35V
RELAY		
K511	50611310	LC2-N DC24V
MISCELLANEOUS		
J511~J514	51221220	Connector, Plug 12P
J515	51221210	Connector, Plug 11P
J516, J517	51221200	Connector, Plug 10P

3-18. POWER SUPPLY PC BOARD ASSY

REF. NO.	PARTS NO.	DESCRIPTION
	51686230	PC Board Assy
	51674711	PC Board
IC's		
U751	51470260	μ A 78M24CU
U752	51470270	μ A 7824CU
TRANSISTORS		
Q751, Q752	51450360	2SC945L (K)
Q753	51450820	2SC2060 (O)
Q755, Q756	50425460	2SA490 (Y)
DIODES		
D751, D752	51430970	Silicon Stack 1B4B1
D753	51430990	Silicon Stack 1B2C1
D754	51430980	Silicon Stack 1B2Z1
D755, D756	51430890	W03C
D757, D758	50425170	1S2473VE
D759, D760	50425170	1S2473VE
D763	50425170	1S2473VE

3-19. MOTOR RELAY PC BOARD ASSY

REF. NO.	PARTS NO.	DESCRIPTION
----------	-----------	-------------

RESISTORS

All resistors are rated $\pm 5\%$ tolerance, 1/4 watt and of carbon type unless otherwise noted.

R751	50570580	100 ohm
R752	51802920	2.7k ohm 1/2W
R753	50570820	1k ohm
R754	50570820	1k ohm
R757	50570820	1k ohm
R760, R761	50527040	2.2k ohm 1W Metal Film
R762, R763	50570940	3.3k ohm
R764	50570940	3.3k ohm
R765, R766	50571060	10k ohm
R767,	50571100	15k ohm
R769	50571280	82k ohm
R770	50571300	100k ohm
R771	50571500	680k ohm

CAPACITORS

C751	50555730	Elec.	3.3 mfd	50V
C754	50554490	Elec.	47 mfd	25V
C755, C756	50554950	Elec.	22 mfd	25V
C757	50554480	Elec.	33 mfd	25V
C758	50555730	Elec.	3.3 mfd	50V
C759	50564400	Elec.	470 mfd	16V
C760	51700340	Elec.	1000 mfd	50V
C761	51700330	Elec.	2200 mfd	63V
C762, C763	50554630	Elec.	100 mfd	35V
C764	51700350	Elec.	2200 mfd	35V
C765	51700340	Elec.	1000 mfd	50V

MISCELLANEOUS

J751	51221140	Connector, Plug 4P
	55550140	Heat Sink, A
	50332910	Insulating Tube
	50332950	Insulating Sheet
	51812070	Jumper, JPW-02-F8 x 3
	57240420	Pin, F-3 Type x 2

REF. NO.	PARTS NO.	DESCRIPTION
----------	-----------	-------------

	51684751	PC Board Assy, B (GENERAL EXPORT)
	51686210	PC Board Assy, C (U.S.A., CANADA)
	51674750	PC Board
Q731	50424670	Transistor, 2SC1317 (R)
D731~D735	51430890	Diode, W03C
D736, D737	50425170	Diode, 1S2473VE
R731, R732	50570820	Carbon Res., 1k ohm 1/4W 5%
R733	50571300	Carbon Res., 100k ohm 1/4W 5%
C731	51700360	Mylar Film Cap., 7 mfd 250V
C732	51700370	Mylar Film Cap., 1.5 mfd 250V (GENERAL EXPORT)
C733	51700360	Mylar Film Cap., 7 mfd 250V
C734	51700370	Mylar Film Cap., 1.5 mfd 250V (GENERAL EXPORT)
C735	50554040	Elec. Cap., 10 mfd 25V
C736	50554530	Elec. Cap., 4.7 mfd 25V
K731	50611310	Relay, LC2-N DC24V
K732~K735	50611150	Relay, LC1-C
S731	50444560	Slide Switch, 6P (GENERAL EXPORT)
Z731~Z740	50529050	Spark Killer, 0.1 mfd + 120 ohm 400V AC
	51812070	Jumper, JPW-02-F8 x 4

3-20. TENSION SERVO SENSOR PC BOARD ASSY

REF. NO.	PARTS NO.	DESCRIPTION
----------	-----------	-------------

	51684720	PC Board Assy
	51674720	PC Board
Q901	51450360	Transistor, 2SC945 (LK)
D901	50425170	Diode, 1S2473VE
R901	50571200	Carbon Res., 39k ohm
R902	50571040	Carbon Res., 8.2k ohm
R903	50570820	Carbon Res., 1k ohm
C901, C902	50554540	Elec. Cap. 1 mfd 50V
C903	50543300	Dip. Mica Cap., 150 pfd 50V
C904	50548780	Mylar Cap., 0.001 mfd 50V 5%
C905	50543820	Dip Mica Cap., 22 pfd 50V
C906	50549280	Mylar Cap., 0.1 mfd 50V
L901, L902	51600380	Coil, Sensor

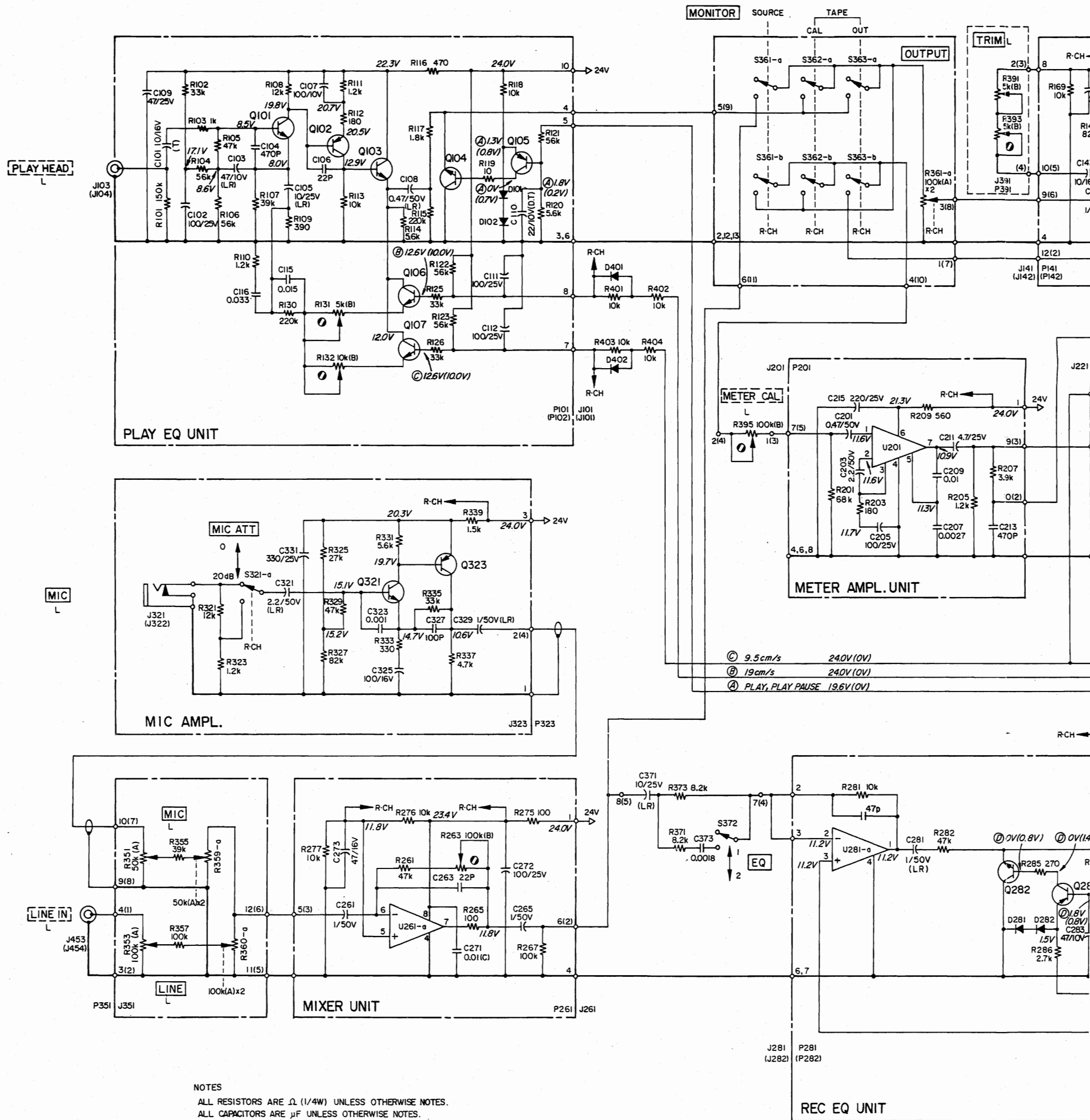

NOTES
 ALL RESISTORS ARE Ω (1/4W) UNLESS OTHERWISE NOTES.
 ALL CAPACITORS ARE μ F UNLESS OTHERWISE NOTES.

REF. NO.	DESCRIPTION	REF. NO.	DESCRIPTION	REF. NO.	DESCRIPTION	REF. NO.	DESCRIPTION
Q101	2SC1327 (T) or 2SC1222 (E)	Q107	2SC693 (G)	Q183	2SC1317 (Q)	Q284	2SC536 (F)
Q102	2SA6661 (S) or 2SA750 (E)	Q141	2SC536 (F)	Q185	2SA719 (Q)	Q285	2SC536 (F)
Q103	2SC536 (F)	Q171	2SC1636 (I)	Q221	2SC536 (G)	Q301	2SC1317 (R)
Q104	2SC536 (F)	Q173	2SA6661 (S) or 2SA733 (P)	Q223	2SC536 (G)	Q302	2SC536 (F)
Q105	2SA6661 (S) or 2SA750 (E)	Q175	2SA719 (Q)	Q225	2SC536 (G)	Q321	2SC1000 (BL) or 2SC1222 (E)
Q106	2SC693 (G)	Q181	2SC945 (P) or 2SC536 (G)	Q282	2SC536 (F)	Q322	2SC1000 (BL) or 2SC1222 (E)
				Q283	2SA6661 (S) or 2SA750 (E)	Q301	OSC UNIT

- Ⓐ PLAY, PLAY PAUSE
- Ⓑ 19 cm/s
- Ⓒ 9.5 cm/s
- Ⓓ REC, REC PAUSE

R-CH REC OUT

CONTROL PCB (B)

CONTROL SW PCB

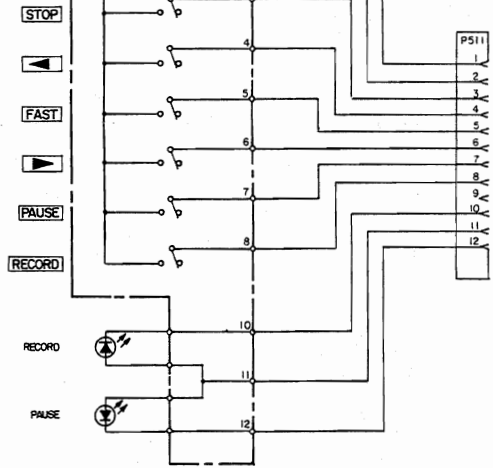

REMOTE CONTROL
TIMER CONTROL

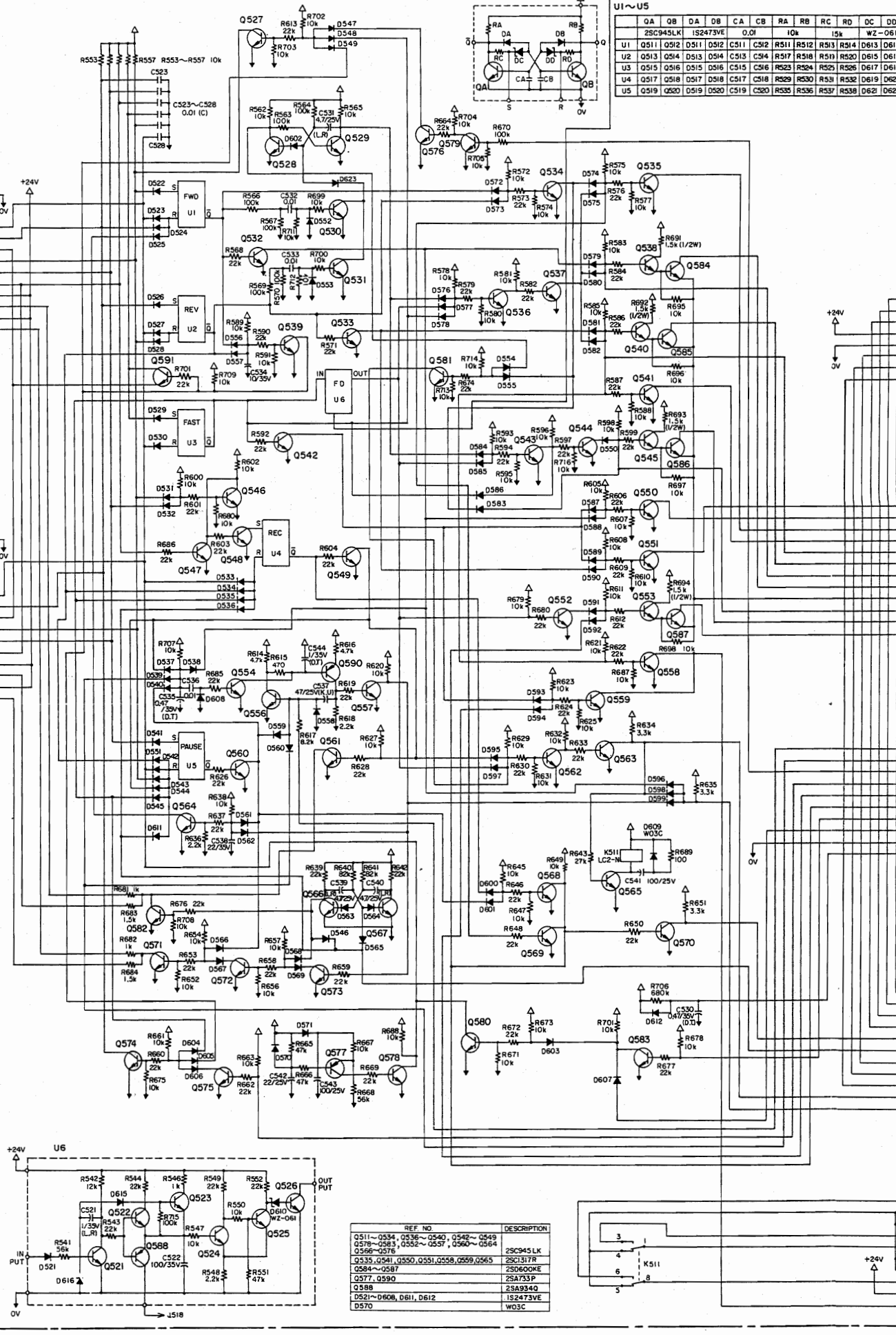
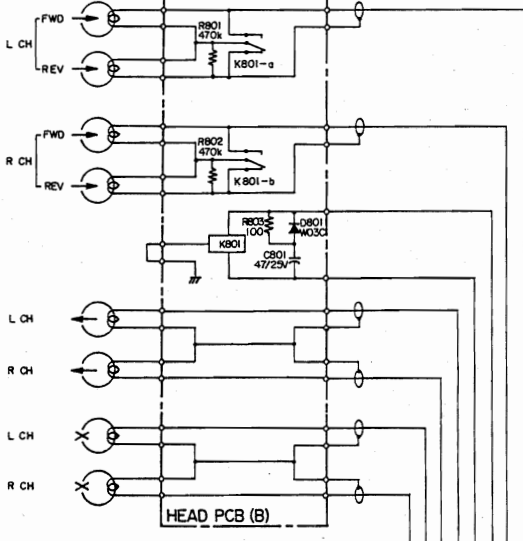
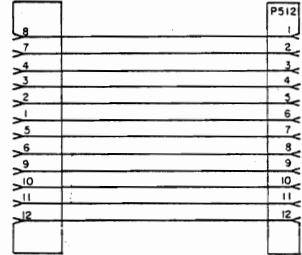

U1~U5	QA	QB	DA	DB	CA	CB	RA	RB	RC	RD	DC	DD
	28C945LK	1S2473VE	0.01	10k	15k	15k	W2-061					
U1	Q511	Q512	D511	D512	C511	C512	R511	R512	R513	R514	D613	D614
U2	Q515	Q516	D515	D516	C515	C516	R515	R516	R517	R518	D615	D616
U3	Q517	Q518	D517	D518	C517	C518	R517	R518	R519	R520	D617	D618
U4	Q519	Q520	D519	D520	C519	C520	R519	R520	R521	R522	D619	D620
U5	Q521	Q522	D521	D522	C521	C522	R521	R522	R523	R524	D621	D622

REF NO	DESCRIPTION
Q511~Q534, Q536~Q540, Q542~Q549	28C945LK
D519~D523, D525~D527, Q560~Q564	1S2473VE
Q535, Q541, Q550, Q551, Q558, Q559, Q565	28C1317R
Q584~Q587	28D600KE
Q577, Q590	28A733P
Q588	28A934Q
D521~D528, D611, D612	1S2473VE
D570	W03C

B	DA	DB	CA	CB	RA	RB	RC	RD	DC	DD
LK	IS2473VE	0.01	10k	10k	WZ-061					
R2	DS11	DS12	C511	C512	RS11	RS12	RS13	RS14	D613	D614
R4	DS13	DS14	C513	C514	RS15	RS16	RS17	RS18	D615	D616
R6	DS15	DS16	C515	C516	RS19	RS20	RS21	RS22	D617	D618
R8	DS17	DS18	C517	C518	RS23	RS24	RS25	RS26	D619	D620
R10	DS19	DS20	C519	C520	RS29	RS30	RS31	RS32	D621	D622

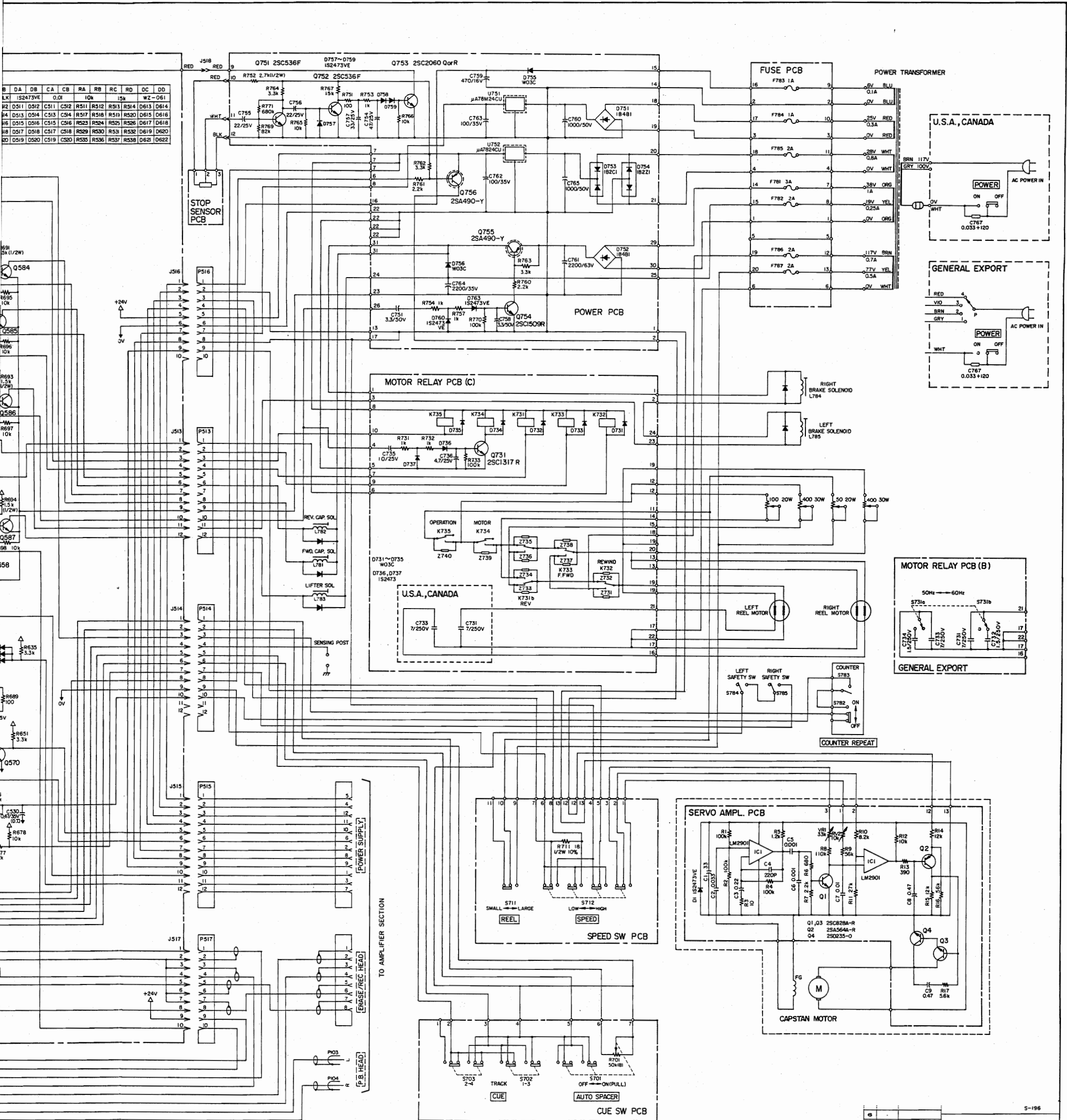

ASSEMBLING HARDWARE CODING LIST

All screws conform to ISO standards, and have crossrecessed heads, unless otherwise noted. ISO screws have the head inscribed with a point as in the figure to the right.

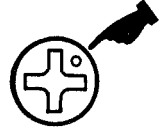

FOR EXAMPLE:

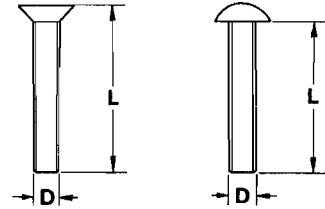
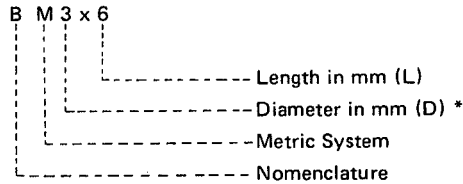

* Inner dia. for washers and nuts

	Code	Name	Type		Code	Name	Type
MACHINE SCREW	R	Round Head Screw		TAPPING SCREW	BTA	Binding Head Tapping Screw(A Type)	
	P	Pan Head Screw			BTB	Binding Head Tapping Screw(B Type)	
	T	Stove Head Screw (Truss)			RTA	Round Head Tapping Screw(A Type)	
	B	Binding Head Screw			RTB	Round Head Tapping Screw(B Type)	
	F	Flat Countersunk Head Screw		SETSCREW	SF	Hex Socket Setscrew(Flat Point)	
	O	Oval Countersunk Head Screw			SC	Hex Socket Setscrew(Cup Point)	
WOOD SCREW	RW	Round Head Wood Screw			SS	Slotted Socket Setscrew(Flat Point)	
	FW	Flat Countersunk Wood Screw		WASHER	E	E-Ring (Retaining Washer)	
	OW	Oval Countersunk Wood Screw			W	Flat Washer (Plain)	
SEMS SCREW	BSA	Binding Head SEMS Screw(A Type)			SW	Lock Washer (Spring)	
	BSB	Binding Head SEMS Screw(B Type)			LWI	Lock Washer (Internal Teeth)	
	BSF	Binding Head SEMS Screw(F Type)			LWE	Lock Washer (External Teeth)	
	PSA	Pan Head SEMS Screw(A Type)		TW	Trim Washer (Countersunk)		
	PSB	Pan Head SEMS Screw(B Type)		NUT	N	Hex Nut	

A-6600 Stereo Tape Deck

TEAC

TEAC CORPORATION 3-7-3, NAKA-CHO, MUSASHINO, TOKYO PHONE: (0422) 53-1111
TEAC CORPORATION OF AMERICA 7733 TELEGRAPH ROAD, MONTEBELLO, CALIFORNIA 90640 PHONE: (213) 726-0303

PRINTED IN JAPAN 0478 SYU 2.0 D-2803A
